

La colección de complementos Rest es se compone de un respaldo de madera universal para bancos de hormigón y un apoyabrazos metálico. Ambos compatibles con un amplio rango de bancos y bancas del catálogo de Escofet para dar respuesta a los requerimientos de accesibilidad y confort, ya sea combinándolos o individualmente. Cumple los requisitos ergonómicos y de usabilidad para facilitar el asiento a las personas de movilidad reducida que precisan de ese soporte. Se fabrica en acero cincado y pintado plata texturizado. Alternativamente en acero inoxidable.

Acero | Madera Certificada FSC® |  400 mm |  3,25 kg

 Update 14.10.2024

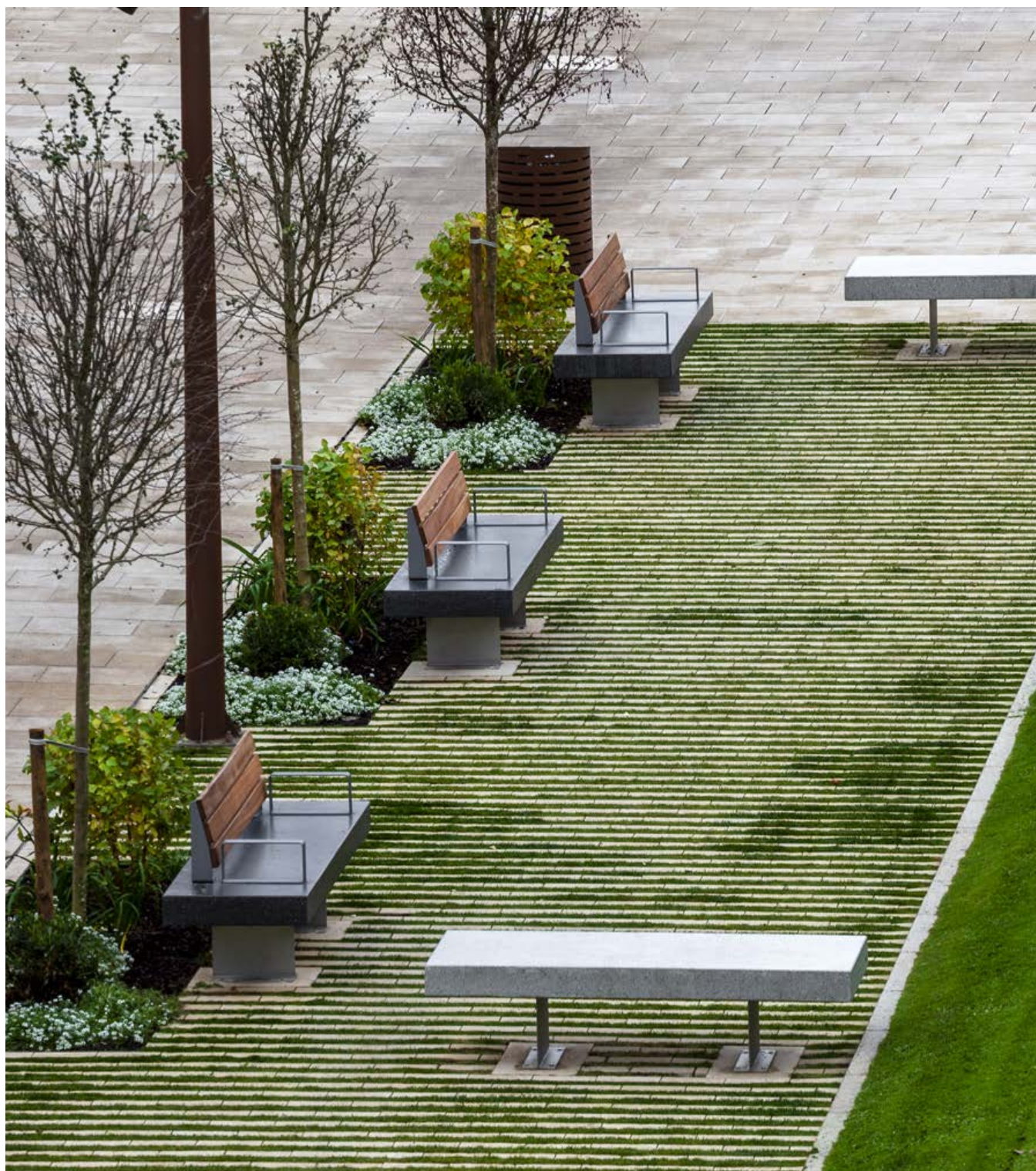

REST

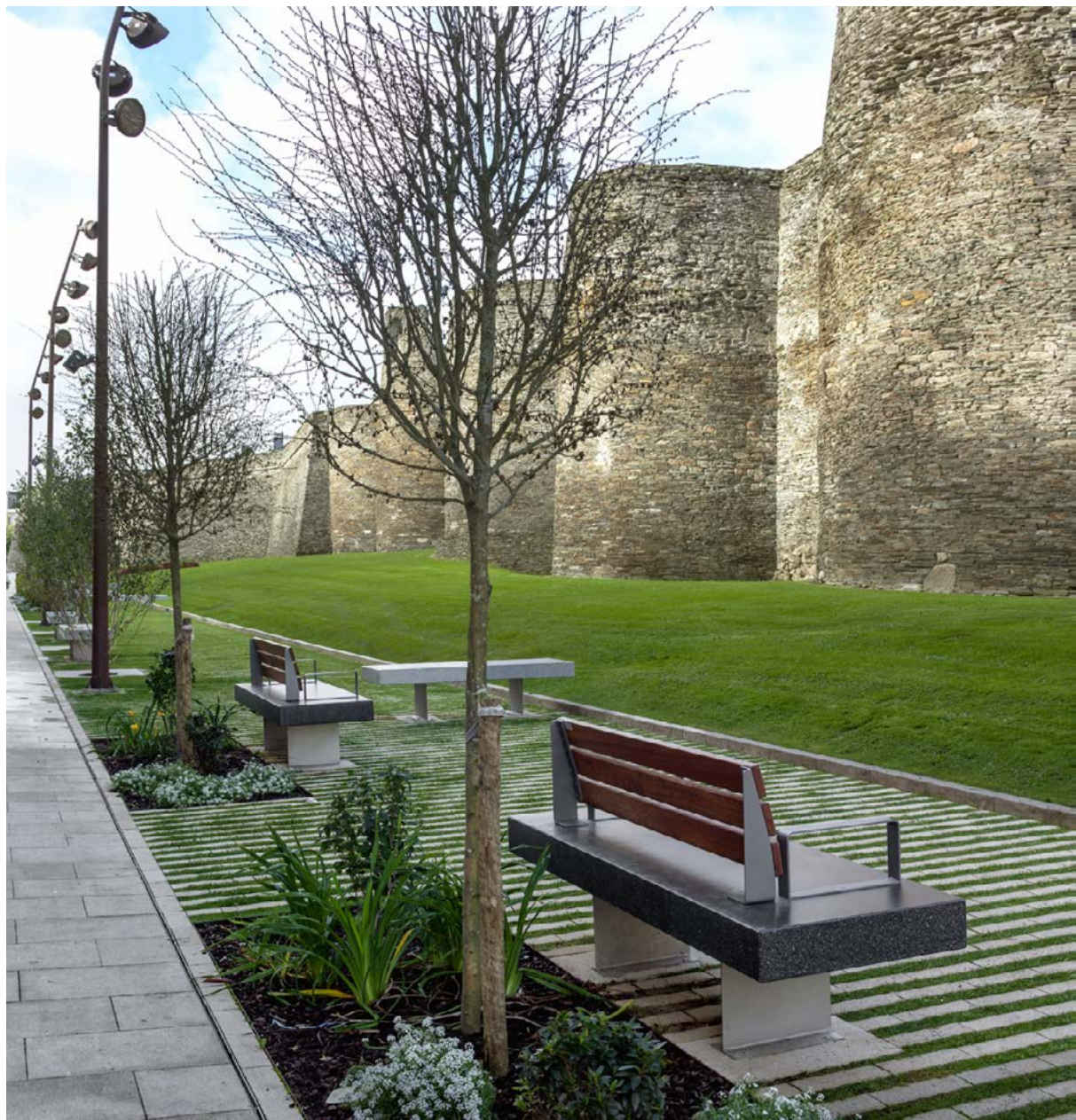

Escofet®

1. Apoyabrazos genérico

Rest Apoyabrazos

Dimensiones 400 x 60 x 200 mm e=6 mm

Peso 3,25 kg

1.1 Características generales

Material Acero zincado
Acero inoxidable

Colocación Anclado en el banco

Acabado Pintado color plata texturizado o RAL con protección frente a la corrosión para una categoría de corrosividad atmosférica C5 según norma UNE-EN ISO 12944-2. / Granallado

Colores



A. Acero plata texturizado **B.** Acero inox. AISI 316

1.2 Geometría

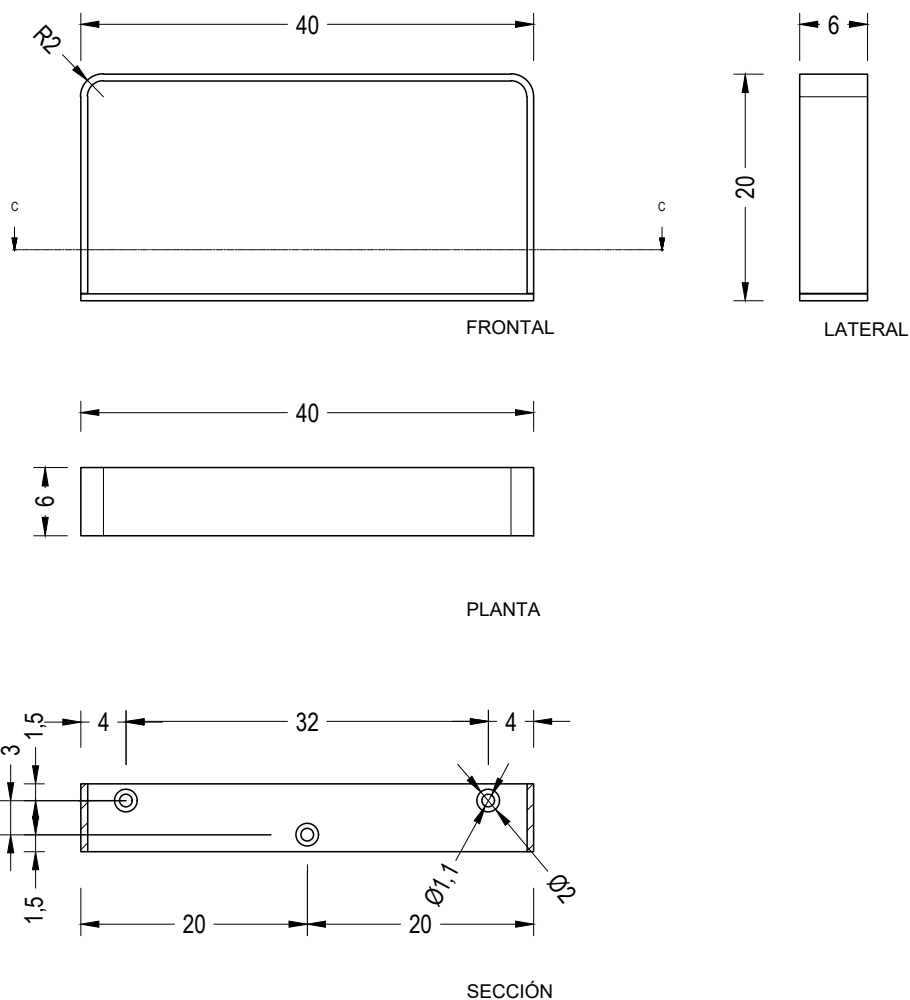

1.3. Sistema de colocación

Rest Apoyabrazos

1. Centrar y colocar el accesorio sobre el banco o muro y marcar agujeros colisos, taladrar el banco o muro y situar el accesorio.

2. Incorpora arandelas de nylon para separar el apoyabrazos del soporte. Insertar y roscar los 3 tacos de expansión 8 x 45mm.

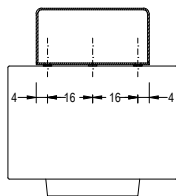
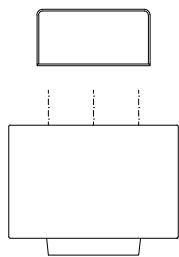

1.4. Compatibilidad Apoyabrazos Rest

SOCRATES + ARMREST

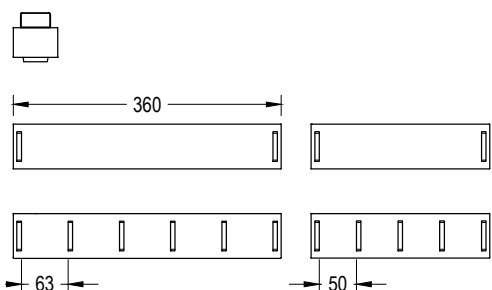

LONGO + ARMREST

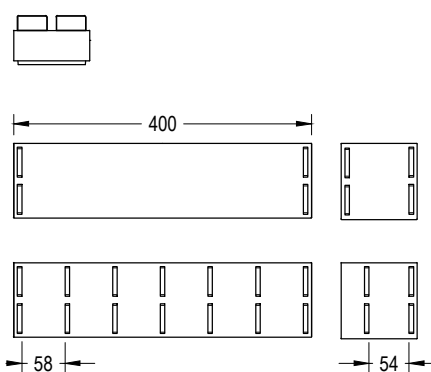

BOX + ARMREST

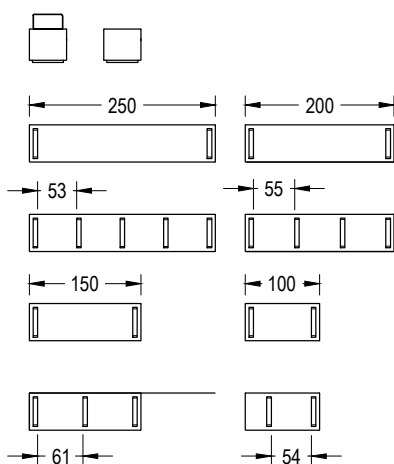

PORTIC + ARMREST

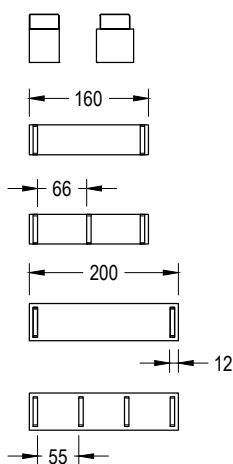

GARONNE + ARMREST

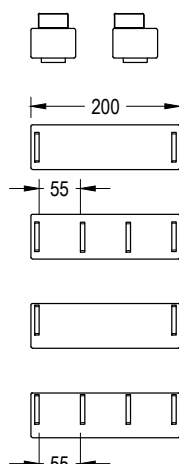

GENEVE + REST

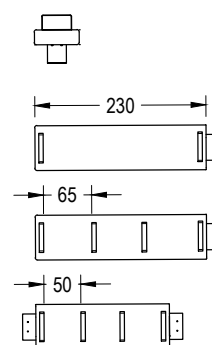

GODOT + ARMREST

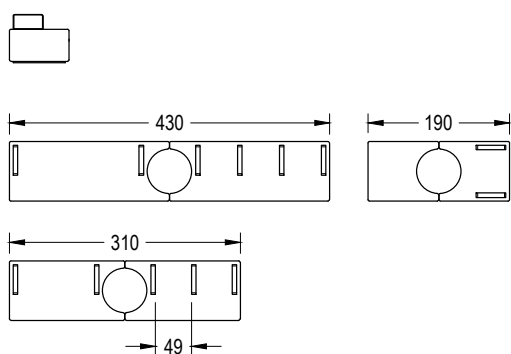

BANCALOSA + ARMREST

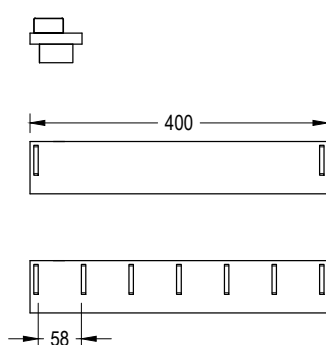

1.4. Compatibilidad Apoyabrazos Rest

Rest Apoyabrazos

LONGO + ARMREST

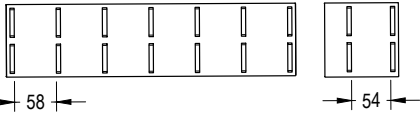
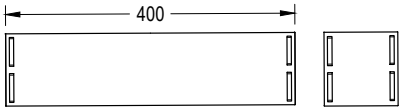

LEVIT + ARMREST

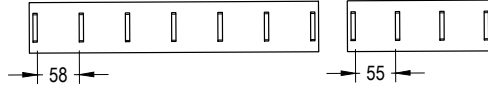
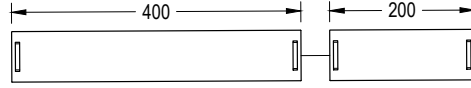
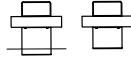

BAND + ARMREST

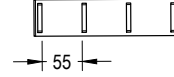
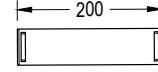

COMU + ARMREST

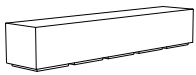
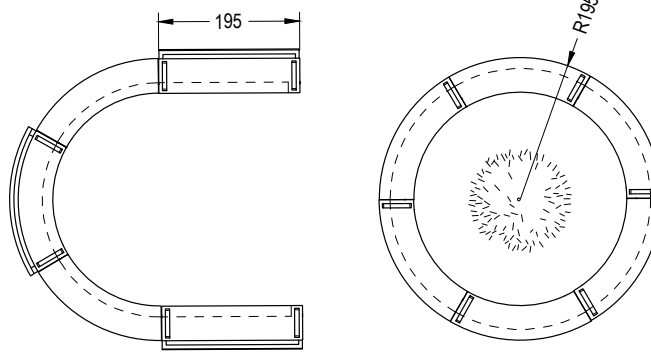
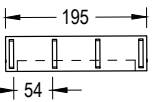
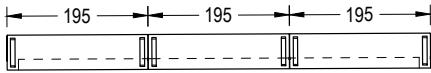

Box



Sócrates

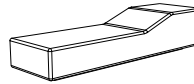

Garonne

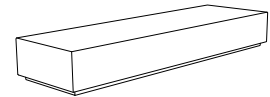

Longo

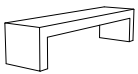

Portic

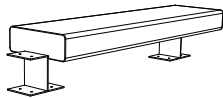

Geneve



Abril

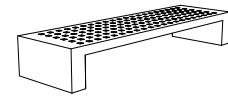

Mayo

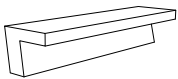

Hydra

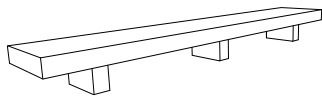

Bancalosa

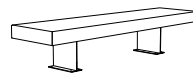

Levit

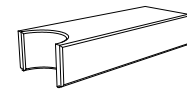

Godot

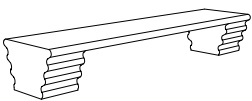

Hebi

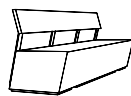

Zuera

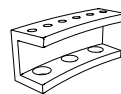

Villette

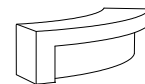

Comú



Band

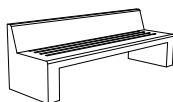

Junio



REST

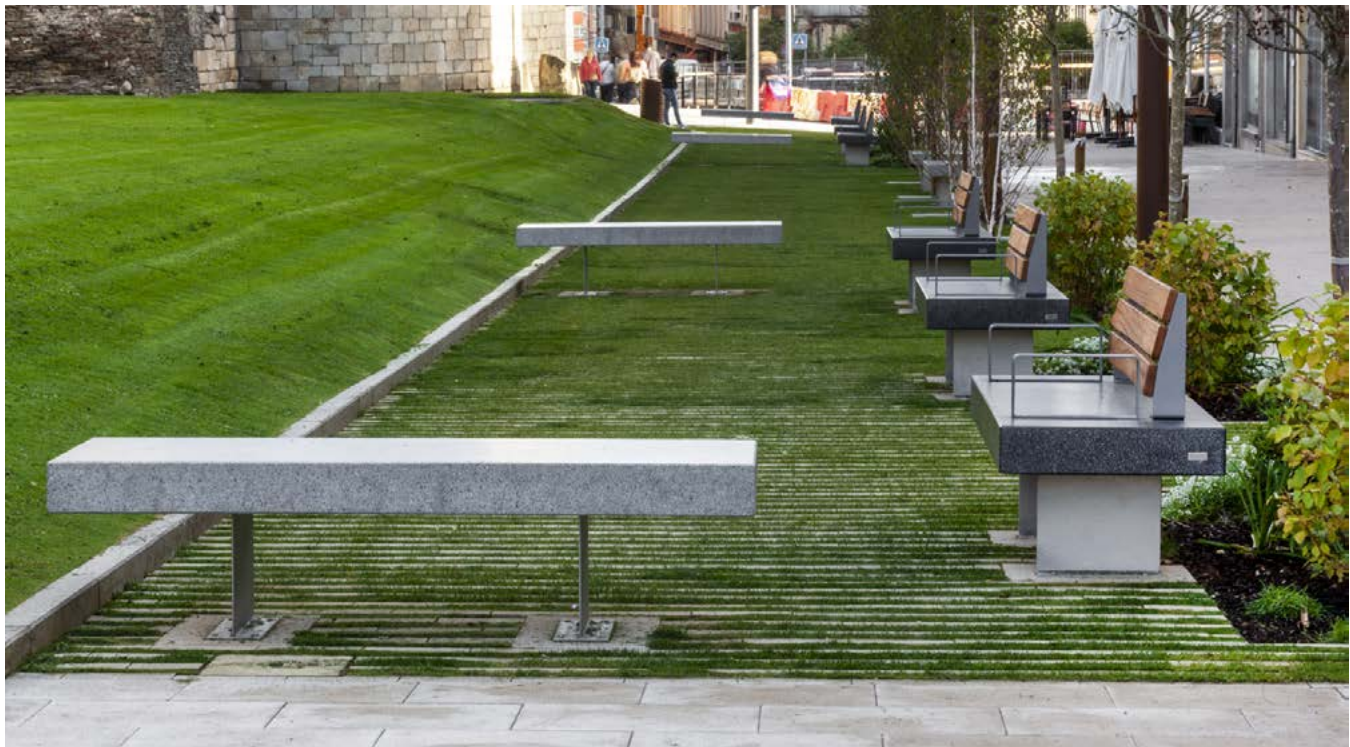

Escofet®

2. Respaldo genérico

Rest Respaldo	150	300
Dimensiones	150 x 13 x 41 cm	300 x 13 x 41 cm

Peso	15 kg	28 kg
-------------	-------	-------

1.1 Características generales

Material	Acero zincado Acero inoxidable	Colocación	Anclado en el banco
-----------------	-----------------------------------	-------------------	---------------------

Acabado	Pintado color plata texturizado o RAL con protección frente a la corrosión para una categoría de corrosividad atmosférica C5 según norma UNE-EN ISO 12944-2. / Granallado		
----------------	---	--	--

Listones	Madera tropical certificada FSC®	Acabado	Tratado con aceite
-----------------	----------------------------------	----------------	--------------------

Colores

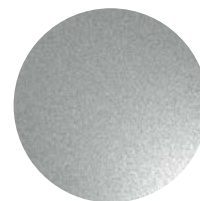
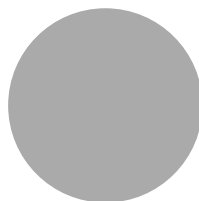

A. Madera tropical Certificada FSC®

B. Acero plata texturizado

C. Acero inox. AISI 316

1.2 Geometría

Rest Respaldo 150

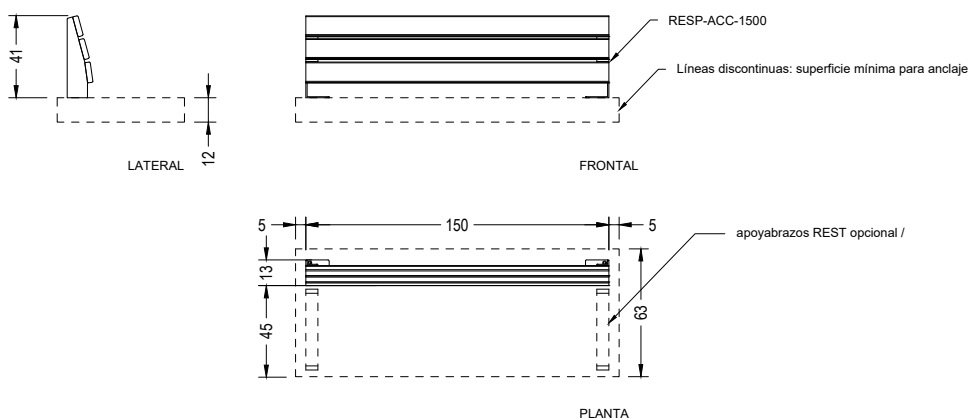

Rest Respaldo 300

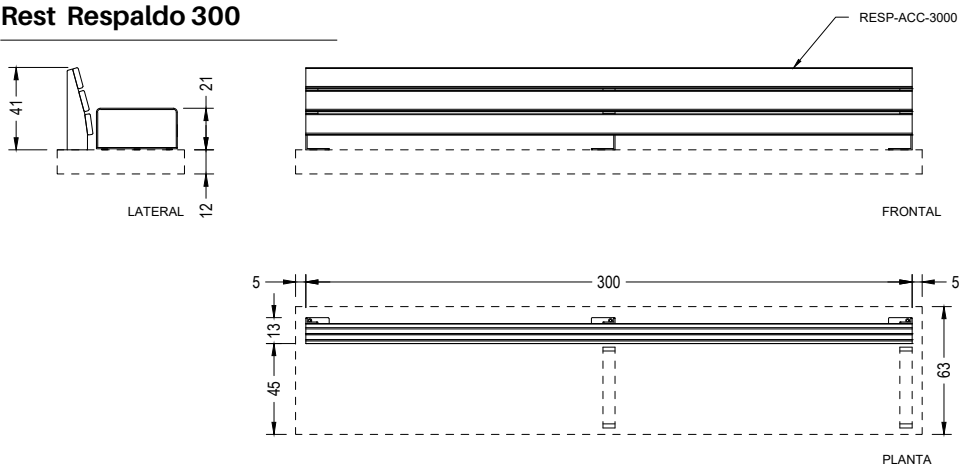

1.3. Sistema de colocación

Rest Respaldo

1. Centrar y colocar el accesorio sobre el banco o muro y marcar agujeros colisos
2. Taladrar el banco o muro y insertar anclaje roscado de expansión

3. Situar el accesorio y roscar los tornillos M-10.
4. Incorpora arandelas de nylon para separar el accesorio del soporte.

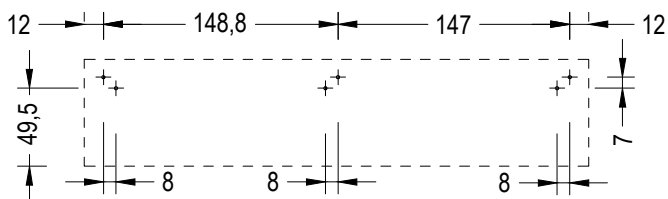
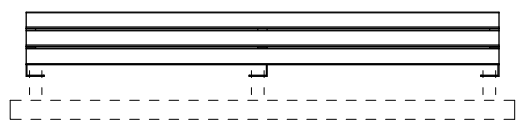
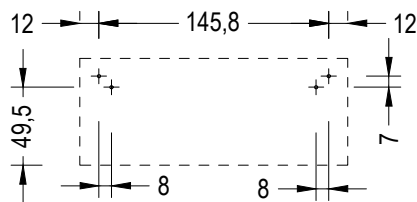
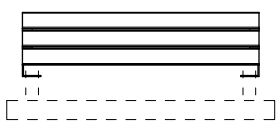

1.4. Compatibilidad Respaldo Rest

SOCRATES + RESPALDO

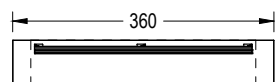
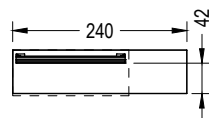

BANCALOSA + BACKREST



GODOT + BACKREST

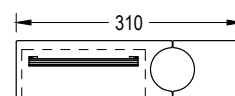
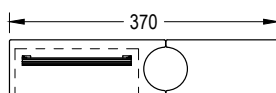
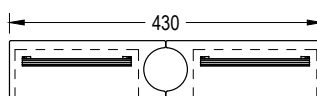

LONGO + BACKREST

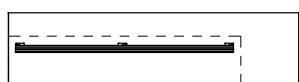
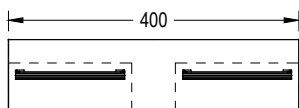

LEVIT + BACKREST

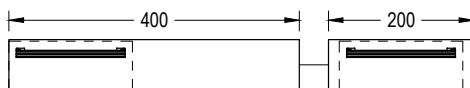

GENEVE + RESPALDO

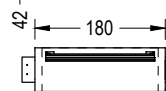
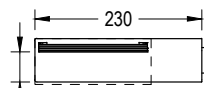

Sócrates

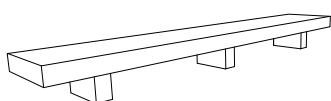

Bancalosa

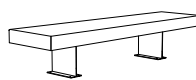

Levit

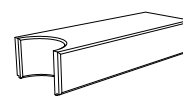

Godot

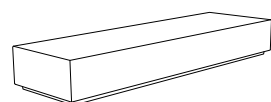

Longo

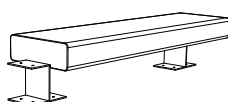

Geneve



Los nombres, marcas y modelos industriales de los productos han sido depositados en los registros correspondientes. La información técnica facilitada por Escofet sobre sus productos puede sufrir modificación sin previo aviso.

Escofet 1886 S.A
Oficina central y producción

Montserrat, 162
E 08760 Martorell
Barcelona - España
T. 0034 937 737 150
F. 0034 937 737 151

info@escofet.com
www.escofet.com



GA-2005/0072 SST-0090/2010 ER-0403/2016