

The *Rest* accessories are a universal metal armrest and a wood backrest for concrete benches. It is compatible with a wide range of products from the Escofet catalogue and it fits to this need either in combination with a backrest or individually. It meets the ergonomic and usability requirements to facilitate seating for people with reduced mobility who need this support. It is made of zinc plated steel and painted textured silver. Alternatively, in stainless steel.

Steel | FSC® Certified Wood |  400 mm |  3,25 kg

 Update 14.10.2024

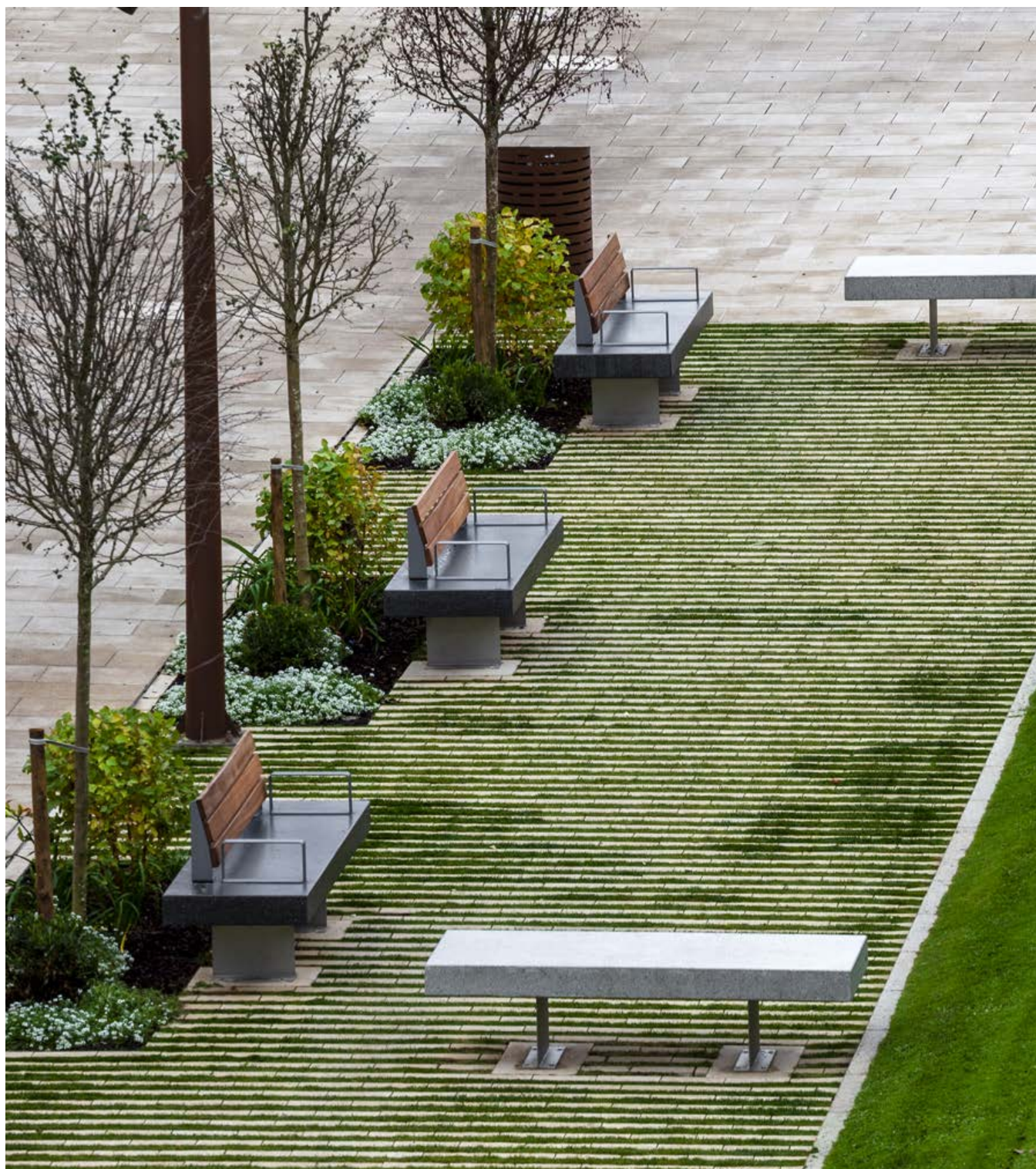

REST

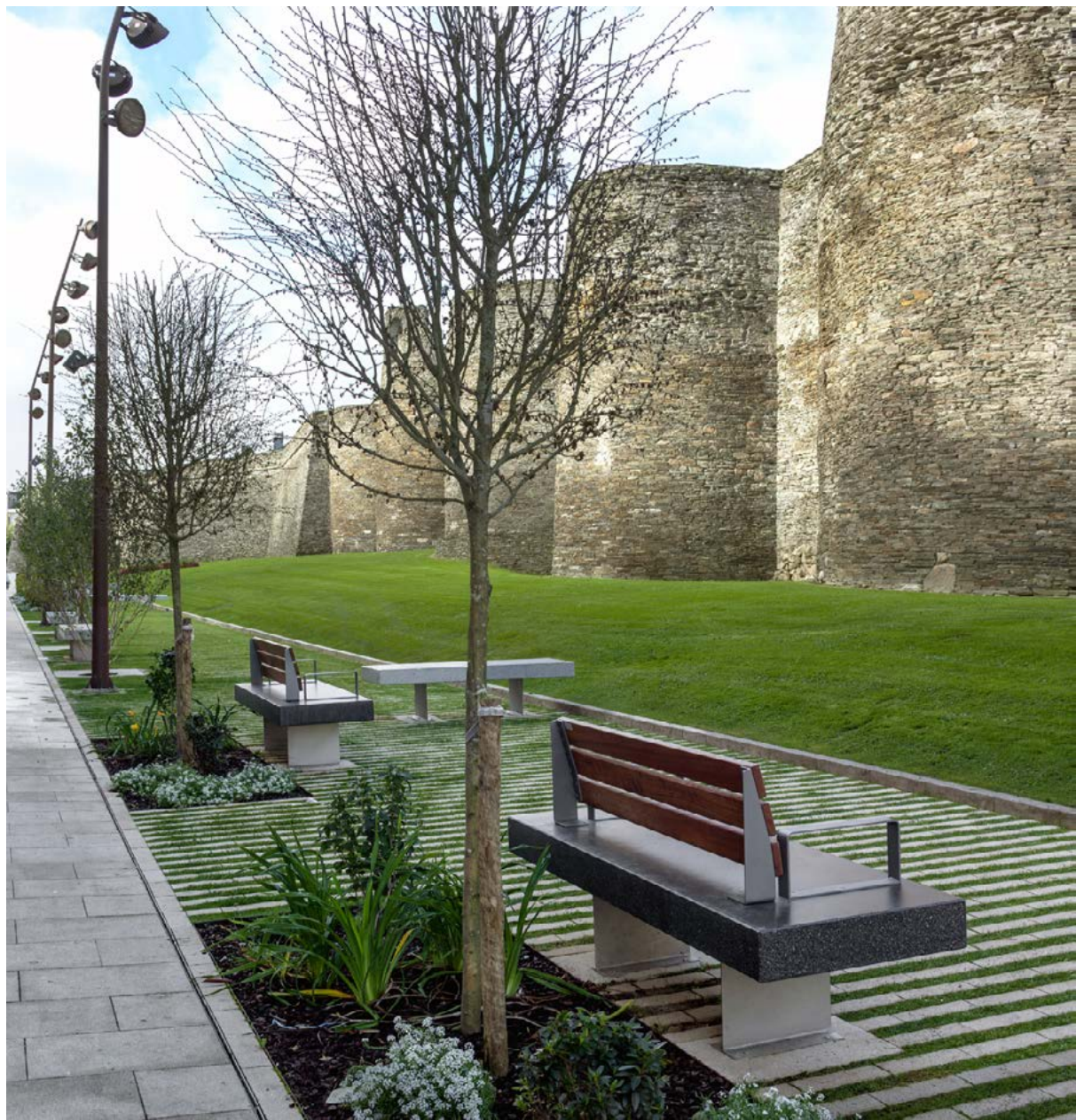

Escofet®

1. Generic armrest

Rest Armrest

Dimensions	400 x 60 x 200 mm	e=6 mm
-------------------	-------------------	--------

Weight	3,25 kg
---------------	---------

1.1 General features

Material	Zinc plated steel Sainless steel	Fixing	Anchored to the bench
-----------------	-------------------------------------	---------------	-----------------------

Finish	Textured Silver coated finish or RAL. Category of atmospheric corrosivity C5 according to UNE EN ISO 12944-2. / Shotblasted
---------------	---

Colours

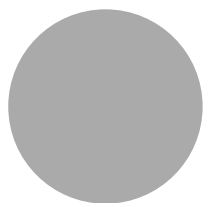

A. Textured Silver steel

B. Sainless steel AISI 316

1.2 Geometry

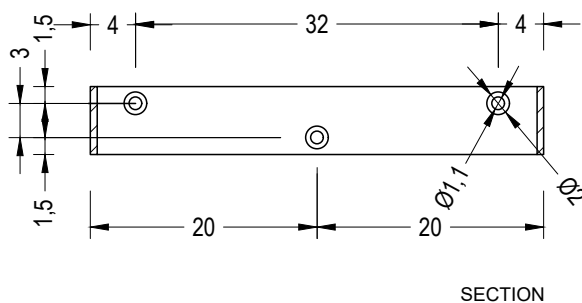
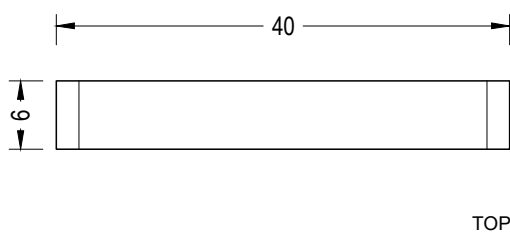
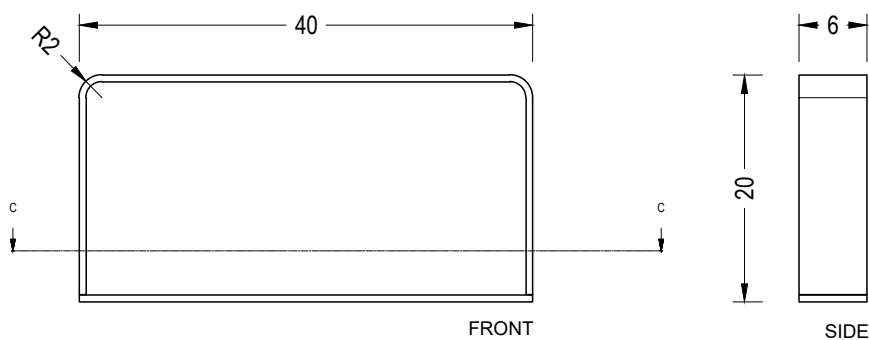

1.3. Installation system

Rest Armrest

1. Centre and position the fitting on the bench or wall and mark the holes, drill the bench or wall and position the fitting.

2. Incorporate the nylon washers to separate the armrest from the support. Insert and screw in the 3 expansion plugs 8 x 45mm.

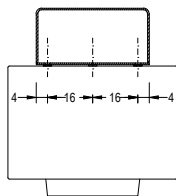
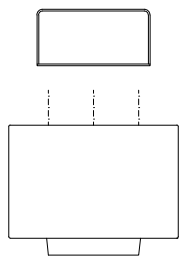

1.4. Compatibility Rest Armrest

SOCRATES + ARMREST

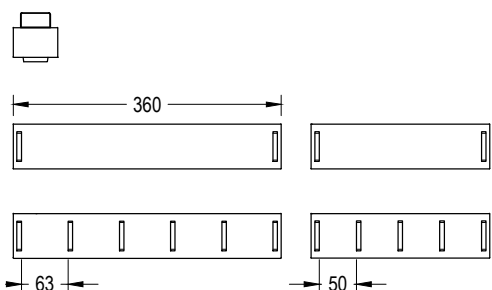

LONGO + ARMREST

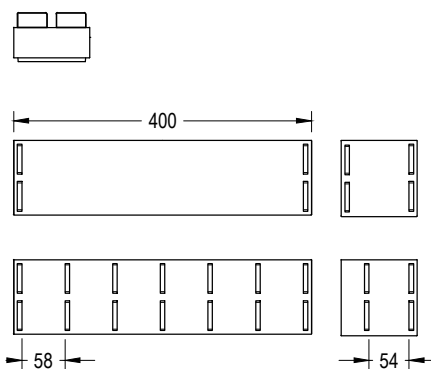

BOX + ARMREST

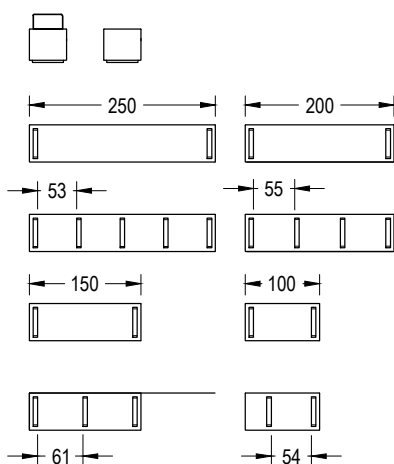

PORTIC + ARMREST

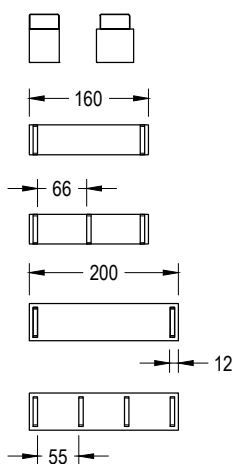

GARONNE + ARMREST

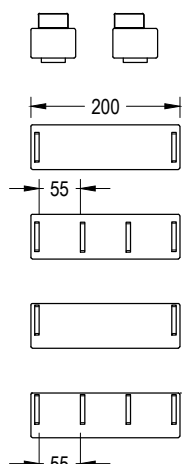

GENEVE + REST

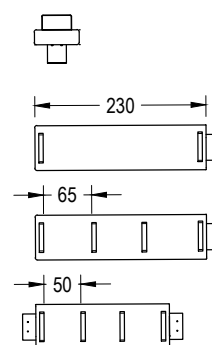

GODOT + ARMREST

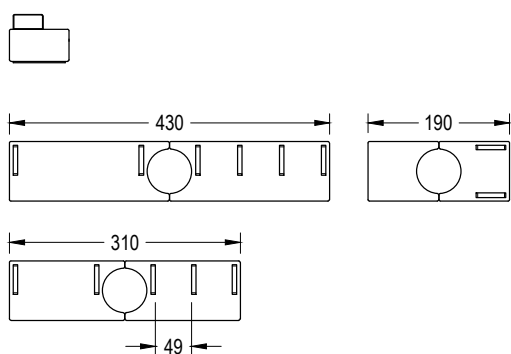

BANCALOSA + ARMREST

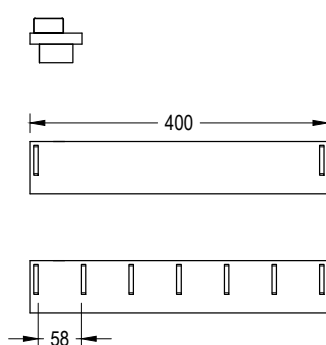

1.4. Compatibility Rest Armrest

Rest Armrest

LONGO + ARMREST

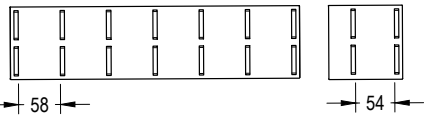
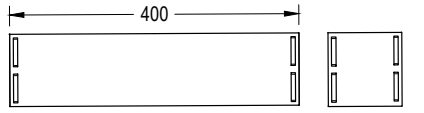

LEVIT + ARMREST

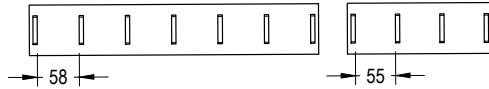
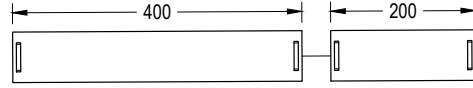
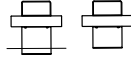

BAND + ARMREST

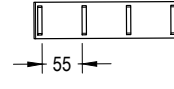
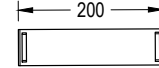

COMU + ARMREST

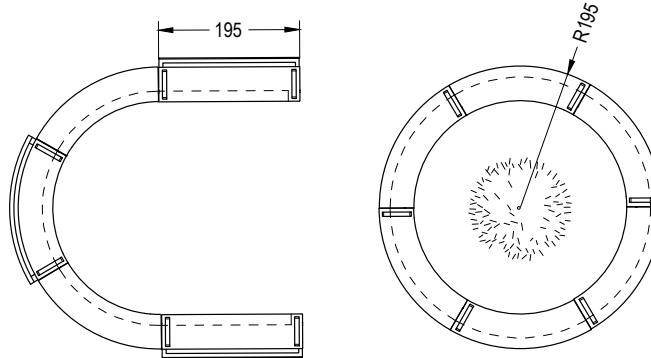
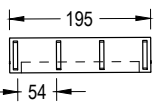
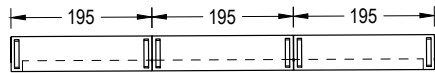

Box



Sócrates

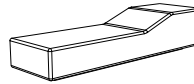

Garonne

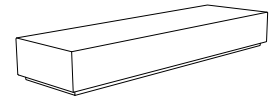

Longo

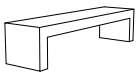

Portic

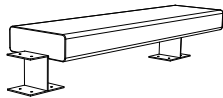

Geneve



Abril

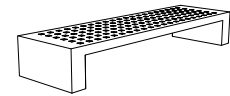

Mayo

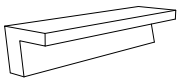

Hydra

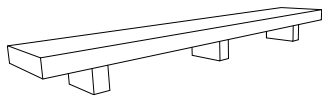

Bancalosa

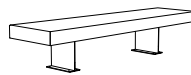

Levit

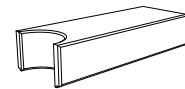

Godot

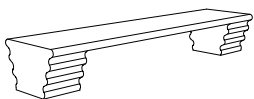

Hebi

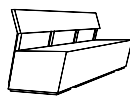

Zuera

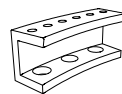

Villette

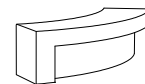

Comú



Band

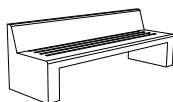

Junio



REST

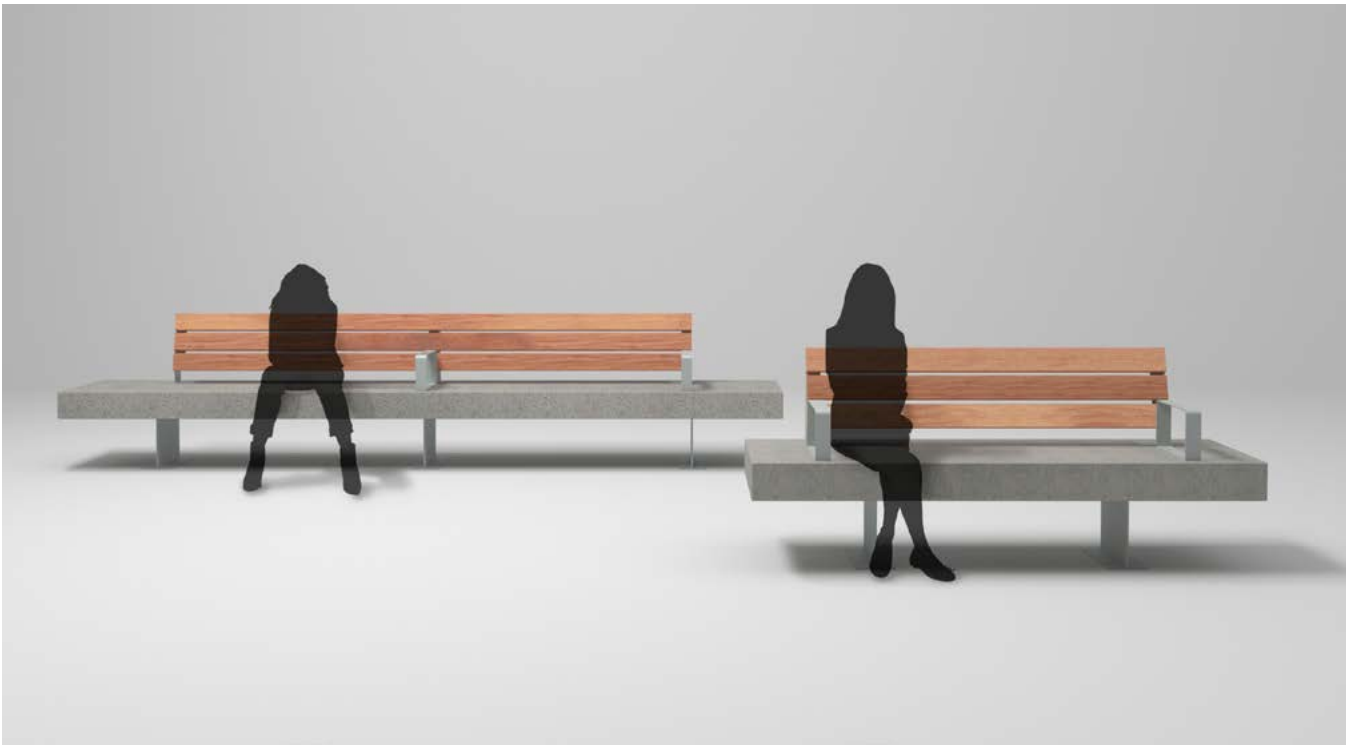
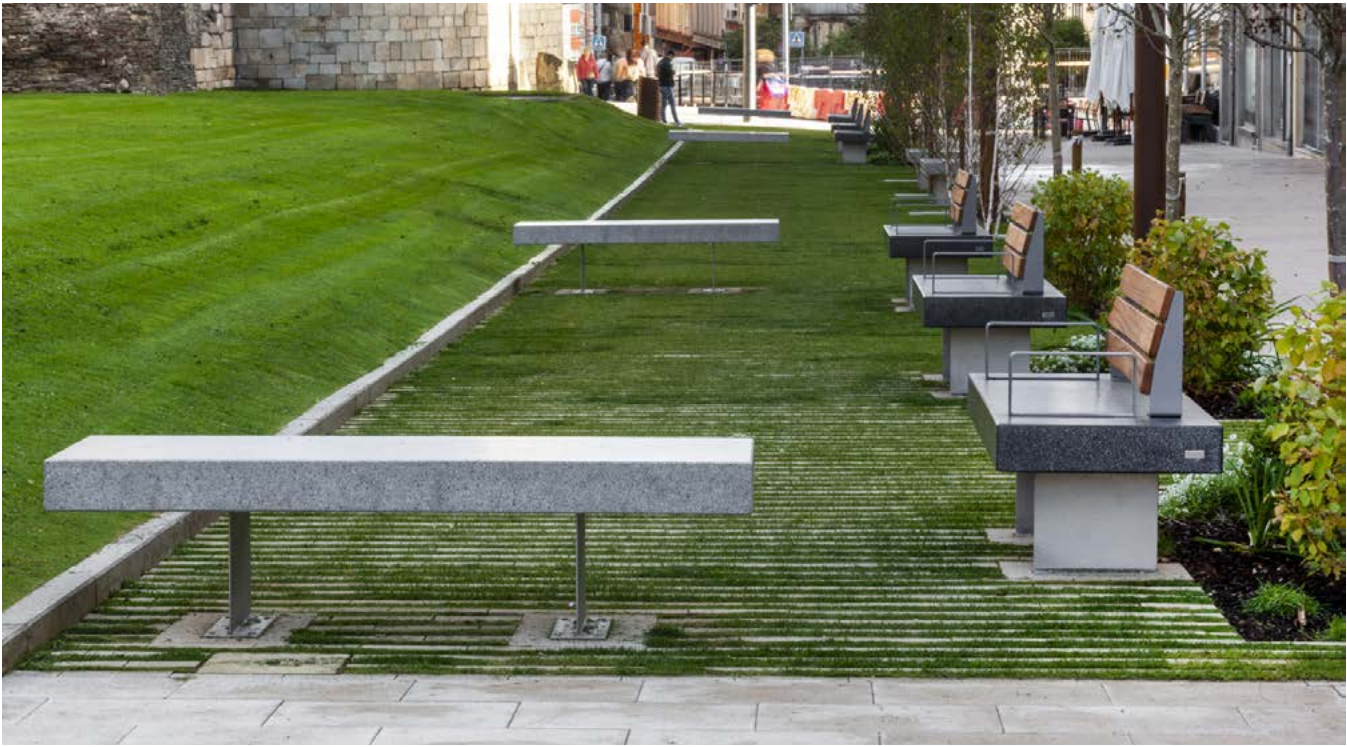

Escofet[®]

2. Generic backrest

Rest Backrest	150	300
Dimensions	150 x 13 x 41 cm	300 x 13 x 41 cm
Weight	15 kg	28 kg
1.1 General features		
Material	Sainless steel Galvanised steel	Fixing Anchored to the bench
Finish	Textured Silver coated finish or RAL. Category of atmospheric corrosivity C5 according to UNE EN ISO 12944-2. / Shotblasted	
Backrest	Tropical wood FSC®	Finish Oil treated

Colours



A. Tropical wood FSC®

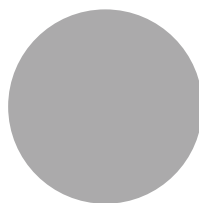

B. Textured Silver steel

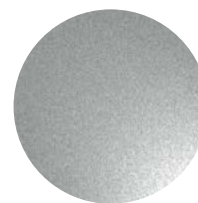

C. Sainless steel AISI 316

1.2 Geometry Rest Backrest

Rest Backrest 150

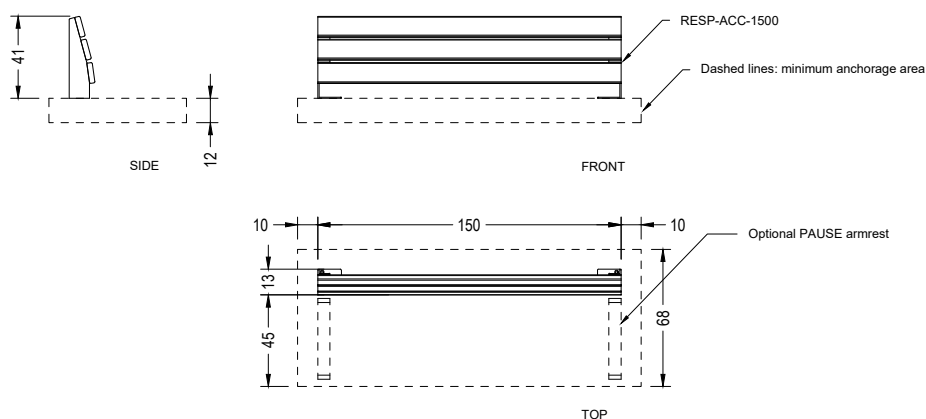

Rest Backrest 300

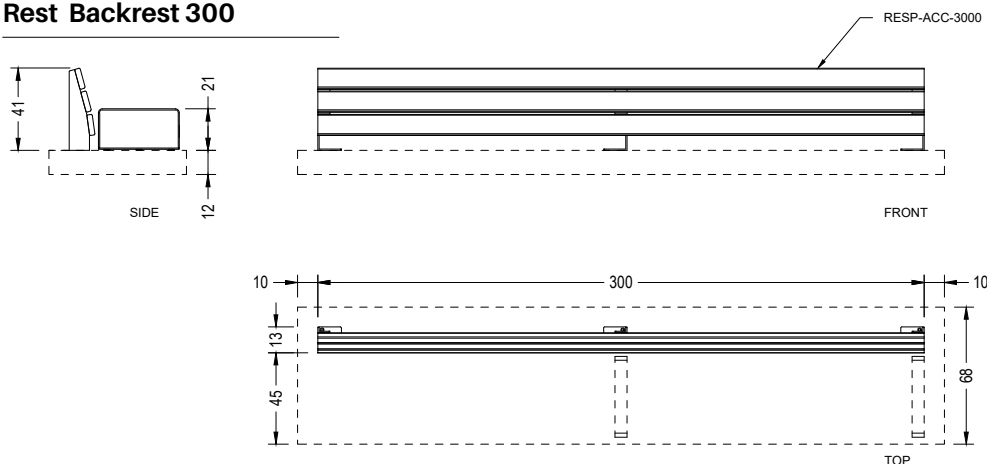

2.3 Installation system

Rest Backrest

1. Center and place the accessory on the bench or retaining wall and mark the slotted holes
2. Drill bench or retaining wall and insert the threaded expansion anchor

3. Place the accessory and tightly the M-10 screws
4. Includes nylon washers to separate the accessory from the support

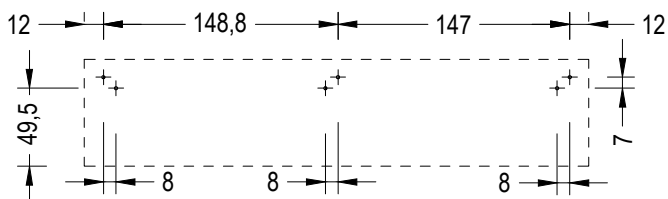
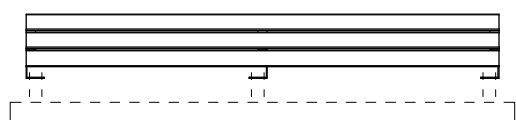
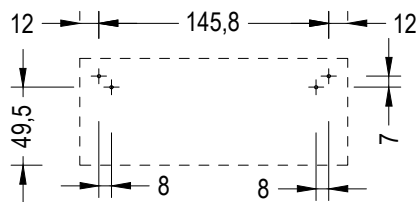
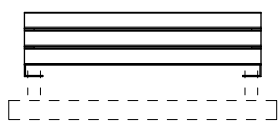

2.4. Compatibility Rest Backrest

SOCRATES + RESPALDO

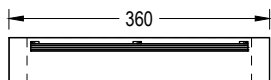
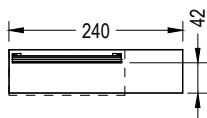

BANCALOSA + BACKREST



GODOT + BACKREST

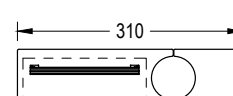
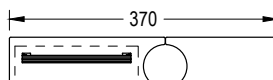
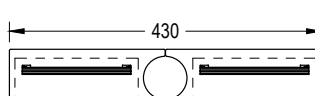

LONGO + BACKREST

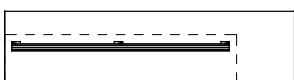
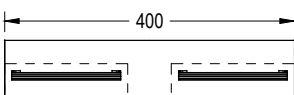

LEVIT + BACKREST

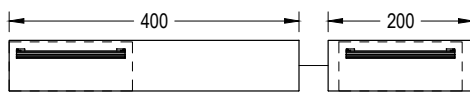
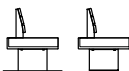

GENEVE + RESPALDO

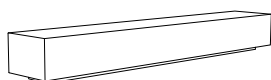
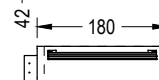
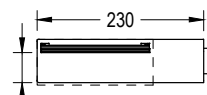

Sócrates

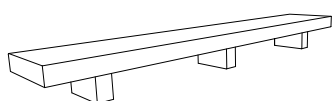

Bancalosa

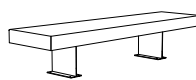

Levit

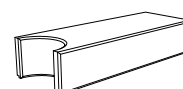

Godot



Longo

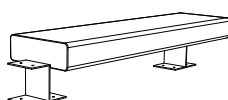

Geneve



The names, trademarks and industrial models of the products have been logged in the corresponding registers. The technical information provided by Escofet about its products can be modified without prior notice.

Escofet 1886 S.A
Head office and production

Montserrat, 162
E 08760 Martorell
Barcelona - España
T. 0034 937 737 150
F. 0034 937 737 151

info@escofet.com
www.escofet.com



GA-2005/0072 SST-0090/2010 ER-0403/2016