







BOX is a basic backless bench that explores concepts already anticipated in other Escofet products. A moulded concrete parallelepiped with clean edges that levitates above its own shadow. The embedded complements of teak wood seat compatible with Box 200, provide comfort and colour to the collection.

Concrete |  250 cm/máx. |  1326 kg |  5

Add-ons:  | 

 Update 09.07.2024



MODULAR

A modular backless bench with a width of 50 cm and variable lengths based on the 50 cm module. With lengths of 250, 200, 150, 100 and 50 cm.

ECOLOGICAL

Environmentally-sustainable product with an external natural stone finish using local recycled aggregates, in a formulation that replaces the use of natural aggregates.

MATERIAL

Moulded concrete, etched finish with recycled aggregate option. Eco-Grey® with recycled concrete aggregates for models manufactured in grey. Optional seat made of solid Teak wood slats, jointed with black elastomer.

INSTALLATION

Resting on the paving, and optionally anchored with two screws threaded through sleeves recessed in base. Sunken baseboard with sling mounting holes to facilitate transport and installation.



BOX



Escofet
by Molins[®]

1. Backless bench

Box	50	100	150	200	250
Dimensions	50 x 50 x 45 cm	100 x 50 x 45 cm	150 x 50 x 45 cm	200 x 50 x 45 cm	250 x 50 x 45 cm
Weigh	265 kg	530 kg	795 kg	1060 kg	1326 kg

1.1 General features

Material	Concrete Recycled concrete	Fixing	Free-standing Anchored with screws
-----------------	-------------------------------	---------------	---------------------------------------

Finish	Etched and waterproofed
---------------	-------------------------

Colours

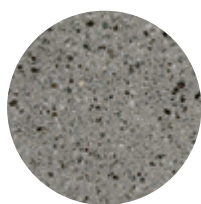

GR. Grey

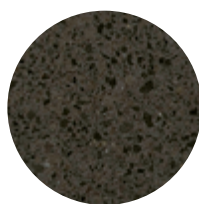

NG. Black

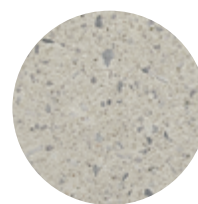

BL. White

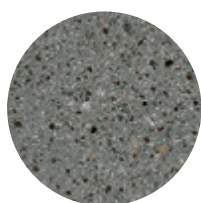

CA. Grey
CA

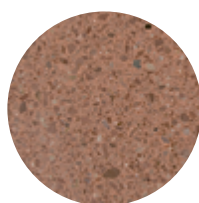

RA. Red

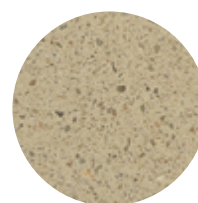

BG. Beige

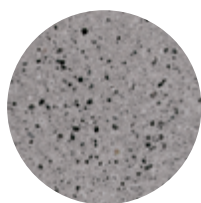

EGR. Eco-Grey®

1.2 Accessories Box 200 specifications

Material	Teak Wood
-----------------	-----------

Colours



A. Teak

1.3 Installation system

Hoisting

(P=265 kg / 530 kg / 795 kg / 1060 kg / 1326 kg)

Installation

Drill pavement $\varnothing 40 \times 180$ mm and fill with resin or fat mortar. Tightly screw the 2 stud bolts Din 931 M16 x 140 mm. Center and caulk the bench foot all around.

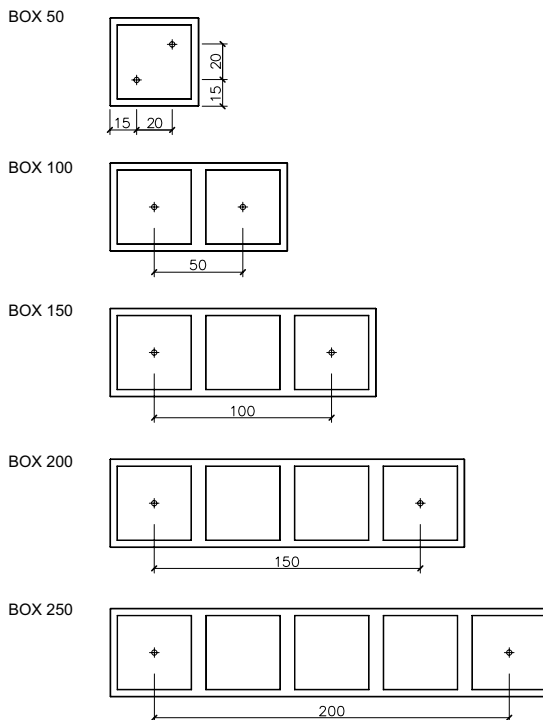
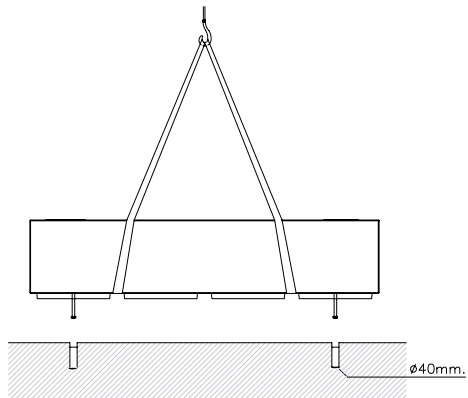

1.4 Geometry

Box 50

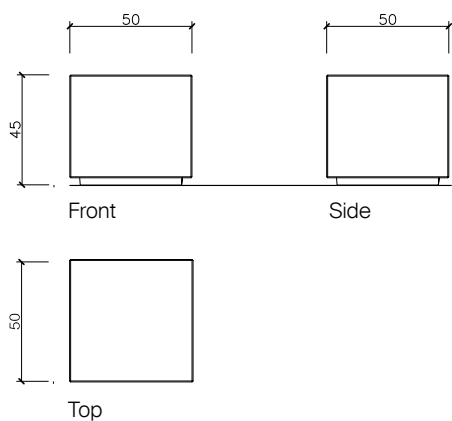

Box 100

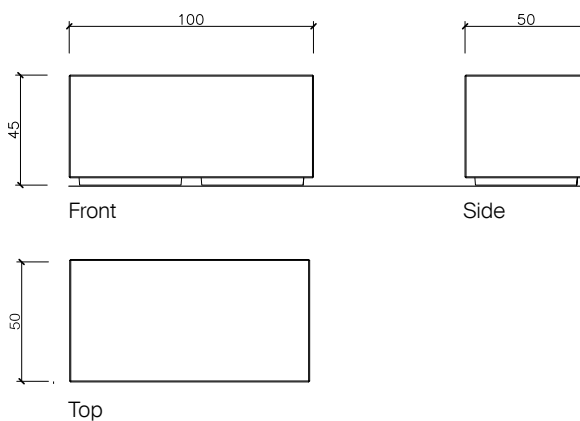

1.4 Geometry

Box 150

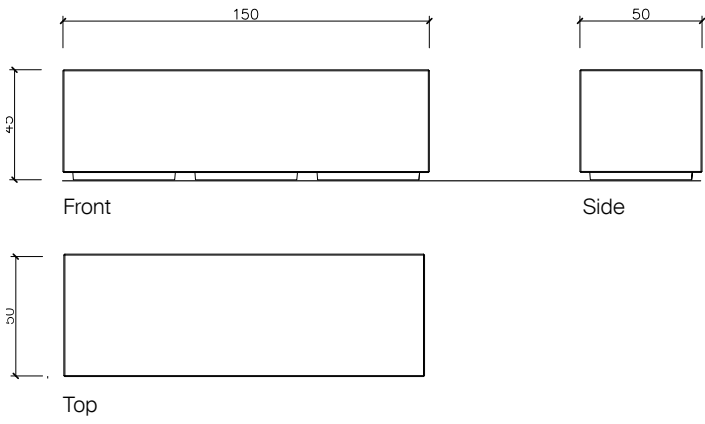

Box 200

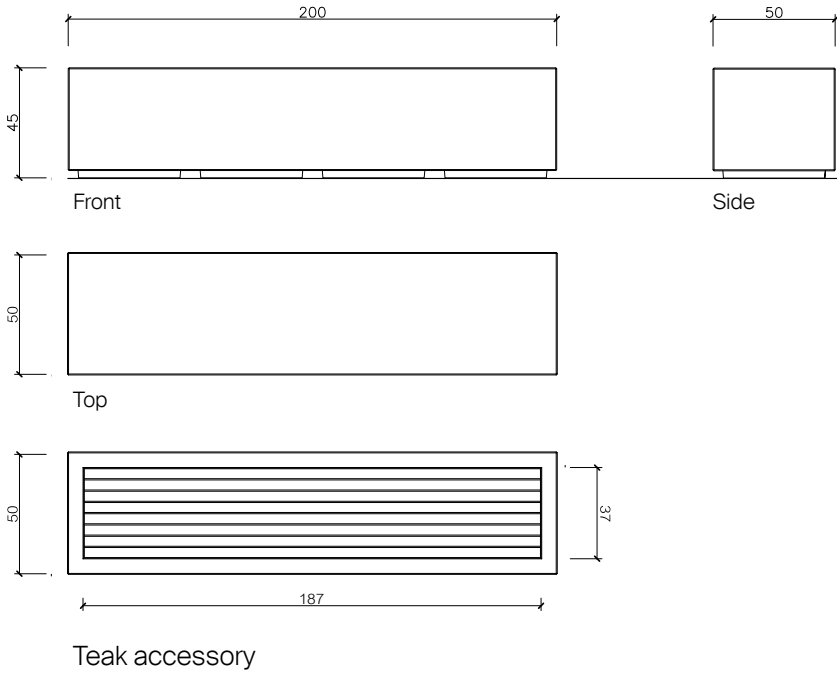

Box 250

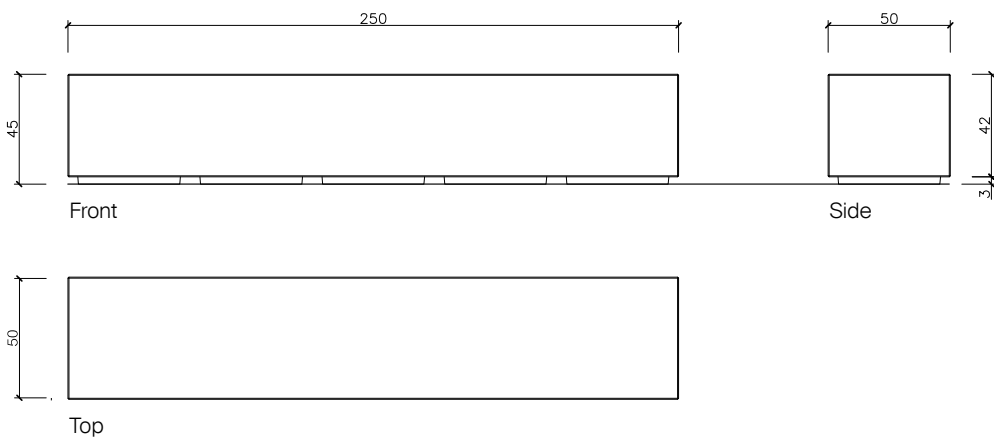

BOX



Escofet
by Molins[®]

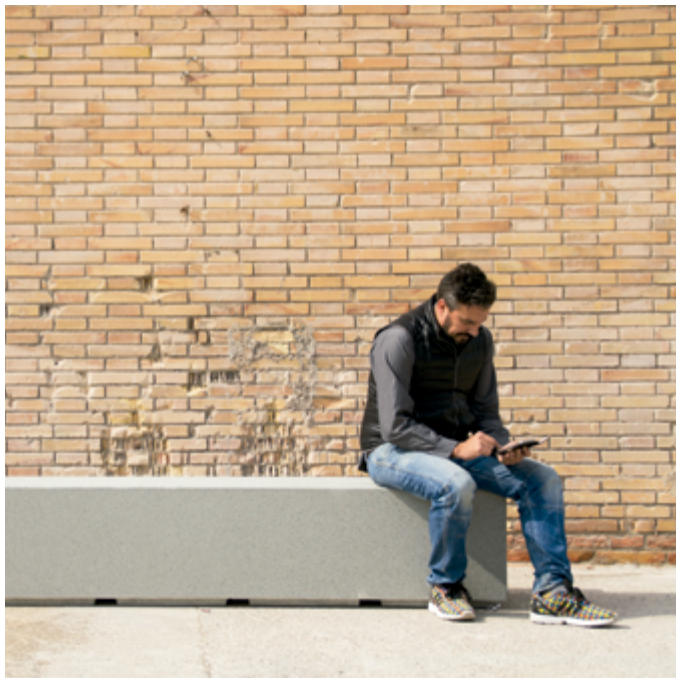

Warranty

5 years in concrete elements.

The names, trademarks and industrial models of the products have been logged in the corresponding registers. The technical information provided by Escofet about its products can be modified without prior notice.

Escofet 1886 S.A
Head office and production

Montserrat, 162
E 08760 Martorell
Barcelona - España
T. 0034 937 737 150
F. 0034 937 737 151

info@escofet.com
www.escofet.com

Escofet
by Molins[®]

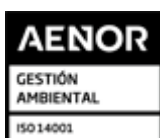

GA-2005/0072



SST-0090/2010



ER-0403/2016



by Molins[®]
Escofet