









BOXLAND est un système modulaire qui permet la formation de multiples agrégations qui inclut tous les composants de la collection Box dans leurs cinq longueurs ainsi que la combinaison avec pentagone d'articulation Nexus. La collection est complétée par les éléments Curve, Radius, Terminal et Box Planter. La composition harmonique de cette suite de produits permet des compositions infinies, simples ou complexes, qui s'adaptent à tout scénario urbain.

Béton |  250 cm/máx. |  1326 kg |  5 |  220 L |  x pcs. | 

 Update 09.07.2024

Option(s):  | 



MODULAIRE

Box banc avec une longueur variable de 250, 200, 150, 100 et 50 cm. et tous les compléments ont une largeur et une hauteur commune de 50 cm pour pouvoir les ajouter de manière modulaire. La jardinière de longueur 200 cm ils peuvent être attachés latéralement et longitudinalement.

Avec l'incorporation de Nexus la modularité est étendue vers des compositions polaires avec un angle de 72° entre les rayons. La banquette et le système Univers et Kanji s'intègre dans n'importe quelle section de Boxland.

ÉCOLOGIQUE

Produit durable du point de vue environnemental, avec une finition externe imitant la pierre naturelle grâce à l'emploi d'agrégats recyclés de proximité; avec une formulation remplaçant les agrégats naturels.

MATÉRIEL

Béton moulé et finition décapée, avec deux options d'agrégat recyclé: Eco-Grey® aux agrégats issus du recyclage du béton pour les modèles de couleur grise. Siège en option fabriqué à partir de lattes en bois massif teck, jointes avec un élastomère noir.

INSTALLATION

Appuyé sur le revêtement de sol et, en option, fixé par deux vis filetées dans des douilles encastrées dans sa base. Socle avec renforcement et canaux de passage de sangles pour en faciliter le transport et l'installation.



BOXLAND



BOXLAND



1. Box Banc sans dossier

Box	50	100	150	200	250
Dimensions	50 x 50 x 45 cm	100 x 50 x 45 cm	150 x 50 x 45 cm	200 x 50 x 45 cm	250 x 50 x 45 cm
Poids	265 kg	530 kg	795 kg	1060 kg	1326 kg

1.1 Caractéristiques générales

Matériel	Béton Béton recyclé	Pose	Ancré avec vis Simplement appuyée
-----------------	------------------------	-------------	--------------------------------------

Finition	Sablé et hydrofugé
-----------------	--------------------

Couleurs

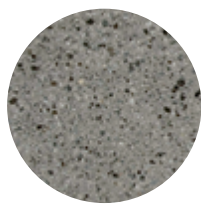

GR. Gris

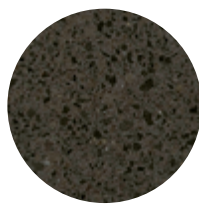

NG. Noir

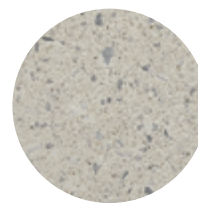

BL. Blanc

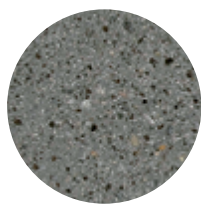

CA. Gris CA

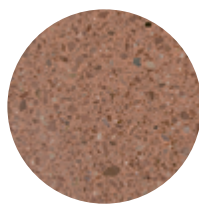

RA. Rouge

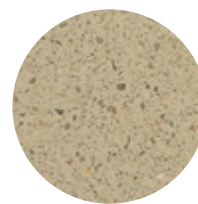

BG. Beige

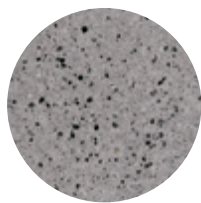

EGR. Gris Eco-Grey®

1.2 Spécifications accessoires Box 200

Matériel	Bois teck
-----------------	-----------

Couleurs



A. Teck

1.3 Système de pose

Élévation

(P=265 kg / 530 kg / 795 kg / 1060 kg / 1326 kg)

Installation

Percer le trottoir avec un foret de Ø40 x 180 mm et remplir avec de la résine. Ensuite, enfiler les 2 vis profondes M16 x 140 mm. Centre, placez le banc et coupez la zone de support.

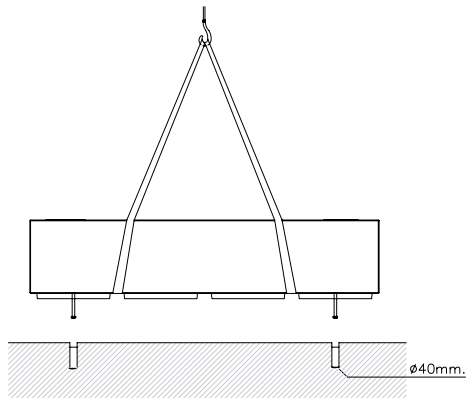

BOX 50

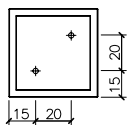

BOX 100

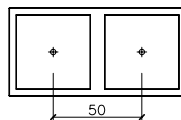

BOX 150

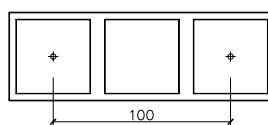

BOX 200

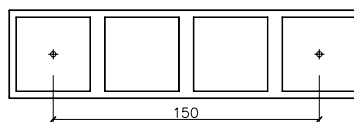

BOX 250

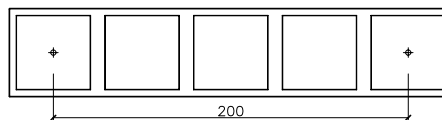

1.4 Géométrie

Box 50

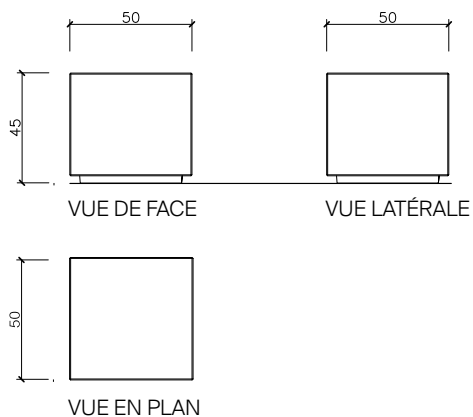

Box 100

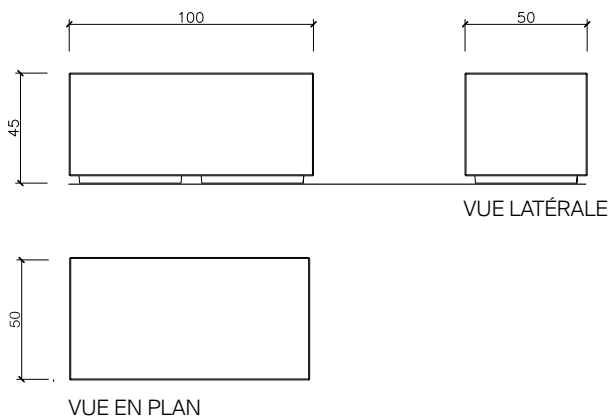

1.4 Géométrie

Box 150

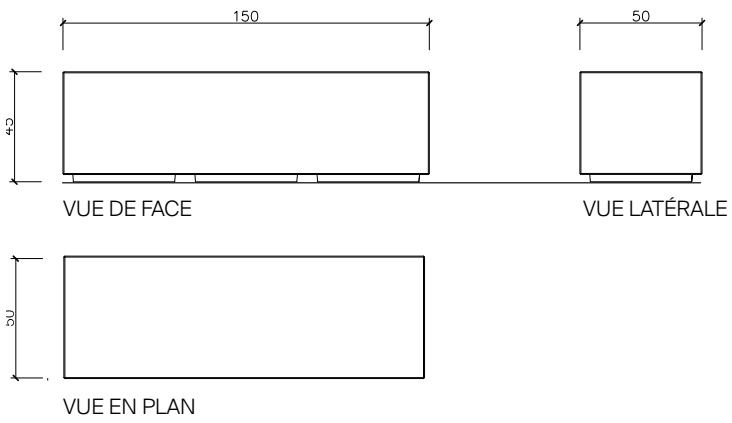

Box 200

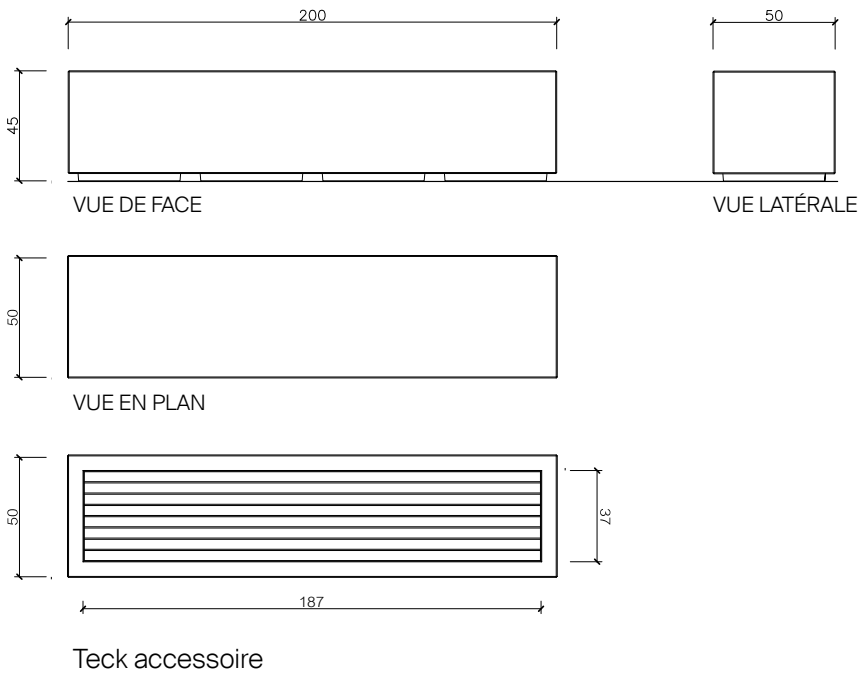

Box 250

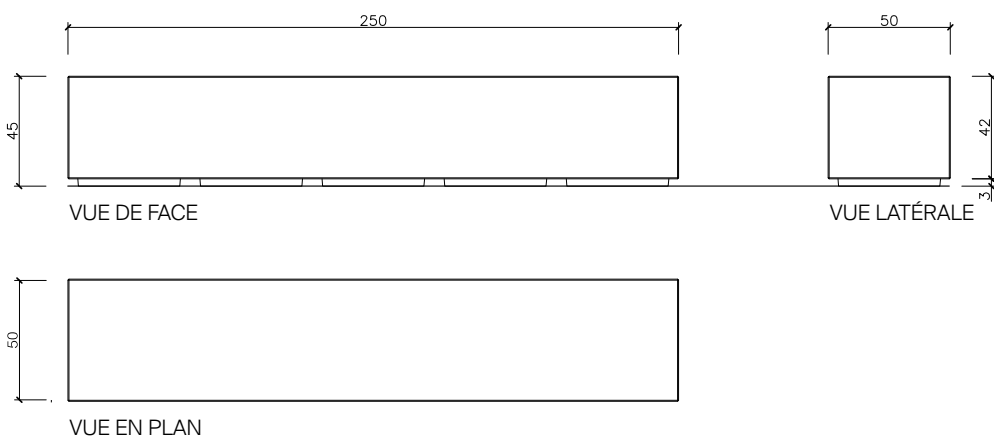

2. Box connecteurs

Box Curve	R100		
Dimensions	200 x 50 x 45 cm		
Poids	1040 kg		
Box Nexus			
Dimensions	81 x 76 x 45 cm		
Poids	450 kg		
Box Radius	45°	90°	120°
Dimensions	52,6 x 42 x 45 cm	60 x 60 x 45 cm	89,5 x 60 x 45 cm
Poids	145 kg	290 kg	388 kg

2.1 Caractéristiques générales

Matériel	Béton Béton recyclé	Pose	Ancré avec vis Simplement appuyée
Finition	Sablé et hydrofugé		

Couleurs

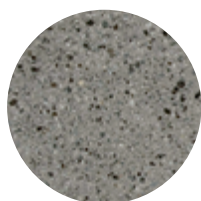

GR. Gris

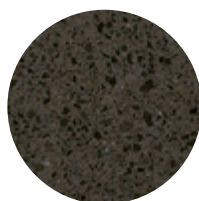

NG. Noir

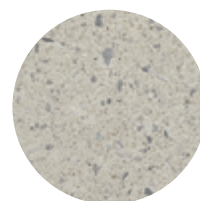

BL. Blanc

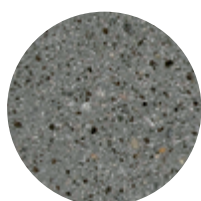

CA. Gris CA

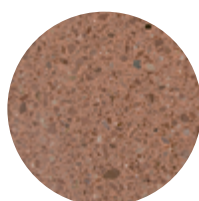

RA. Rouge

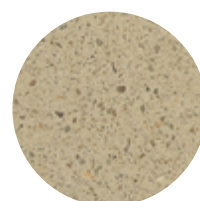

BG. Beige

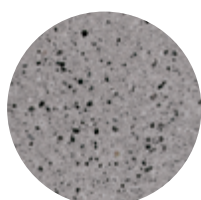

EGR. Gris Eco-Grey®

2.2 Système de pose

Élévation (P=1040 kg)

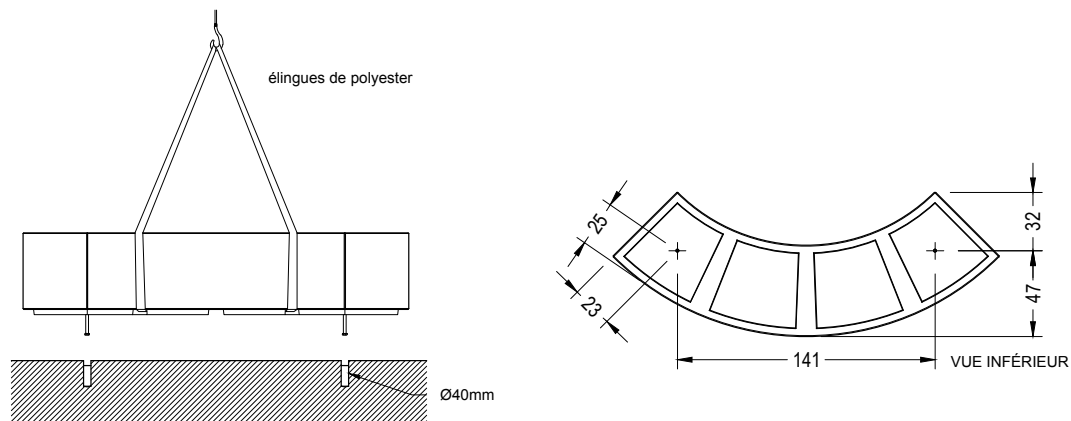

2.3 Géométrie

Box Curve R100

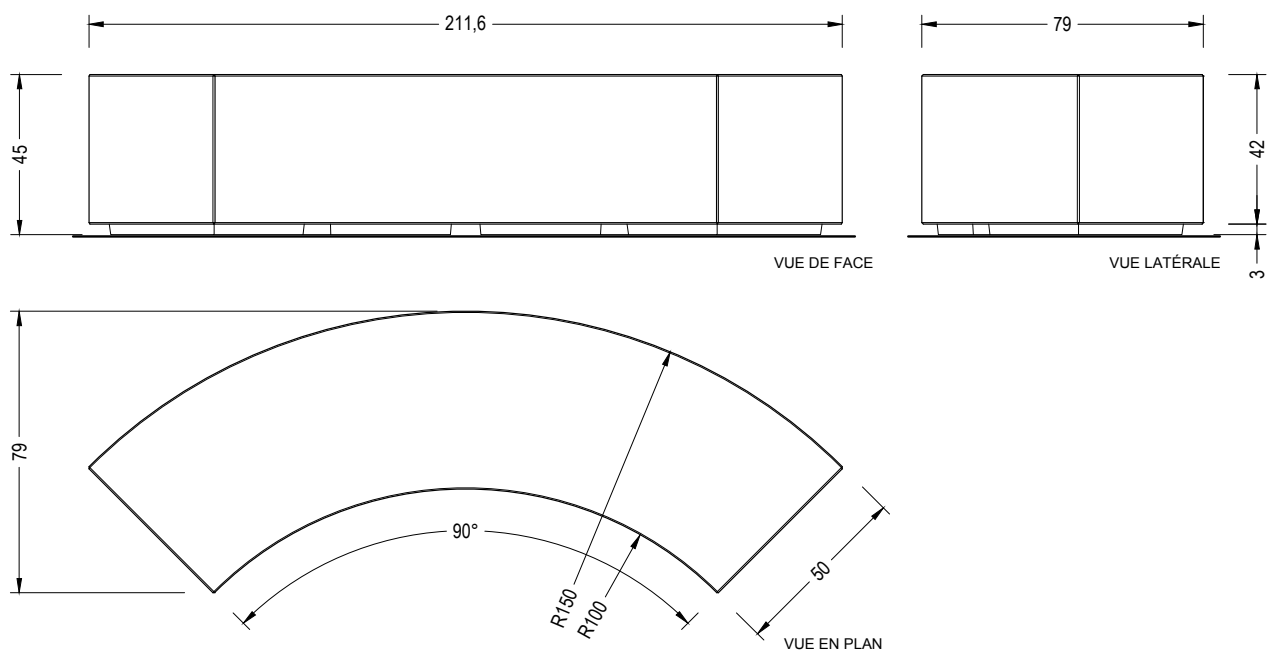

Agrégation 4 Box Curve

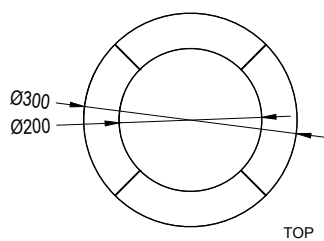

2.2 Système de pose

Élévation (P=450 kg)

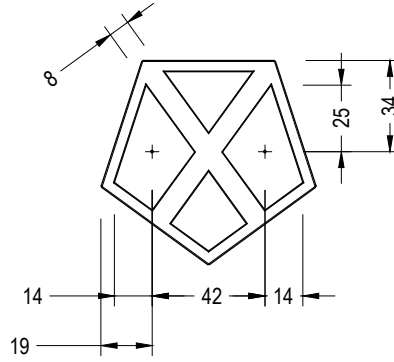
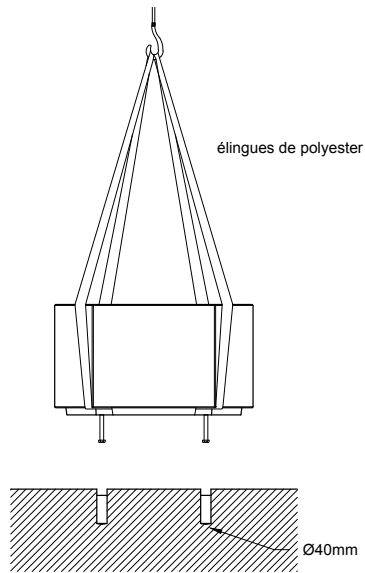

2.3 Géométrie

Box Nexus

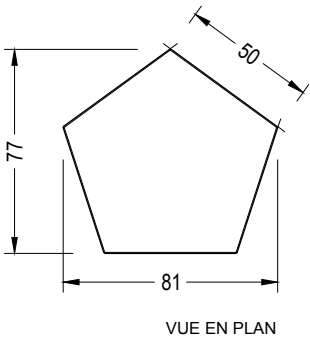
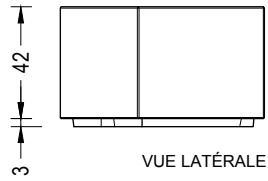
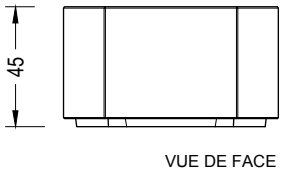

2.2 Système de pose

Élévation

(P=145 kg / 290 kg / 388 kg kg)

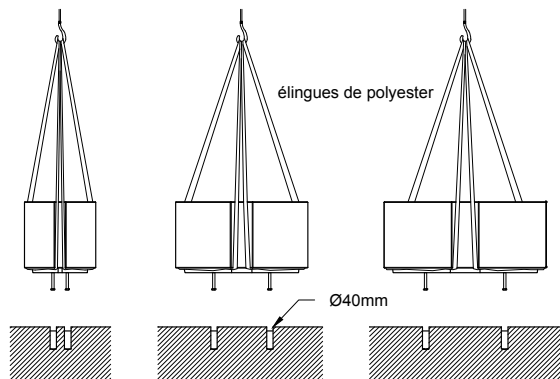

BOX RADIUS 45

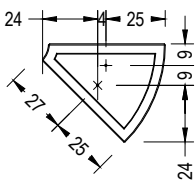

BOX RADIUS 90

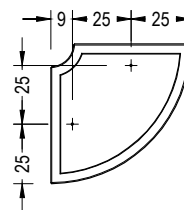

BOX RADIUS 120°

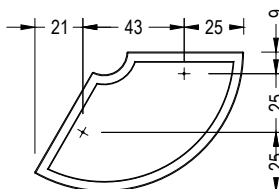

* Box Radius permet des angles personnalisables entre 40° et 180°. Consultez l'OT.

2.3 Géométrie

Box Radius 45°

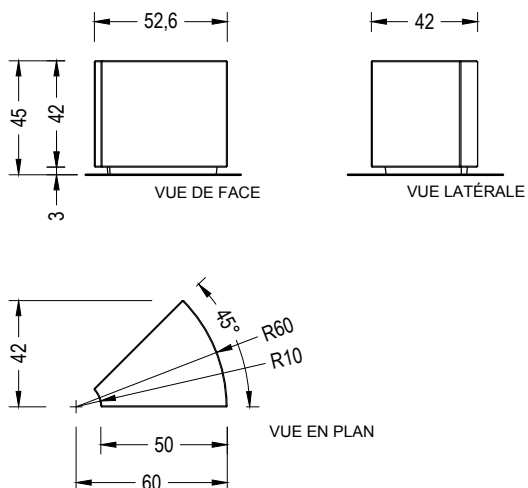

Box Radius 90°

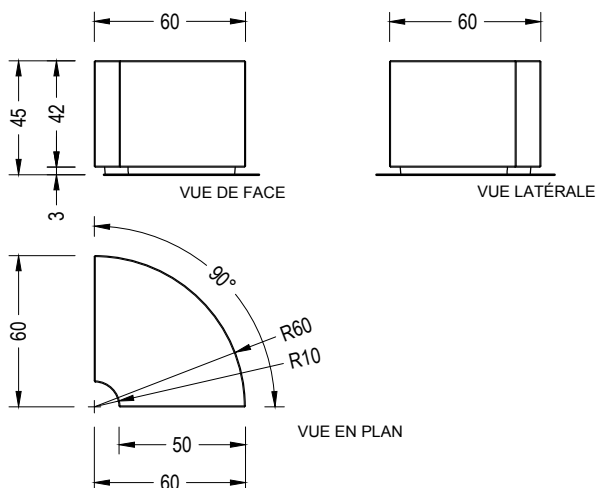

Box Radius 120°

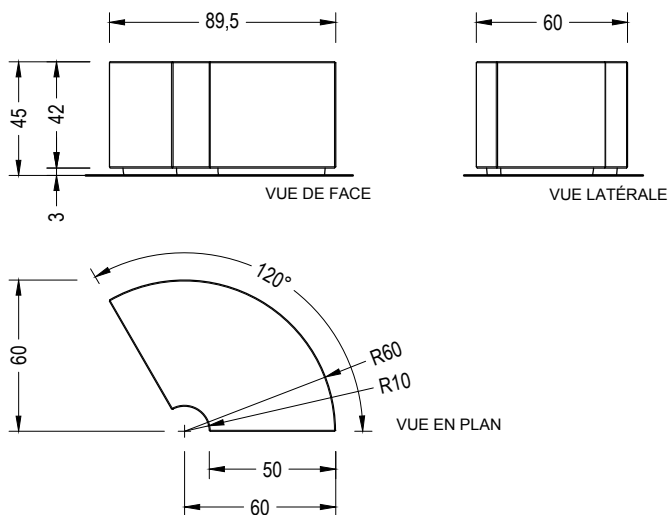

3. Box Terminal

Box Terminal

Dimensions 200 x 50 x 45 cm

Peso 972 kg

3.1 Caractéristiques générales

Matériel	Béton Béton recyclé	Pose	Ancré avec vis Simplement appuyée
-----------------	------------------------	-------------	--------------------------------------

Finition Sablé et hydrofugé

Couleurs

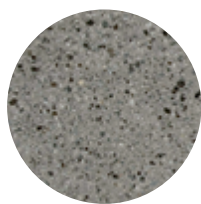

GR. Gris

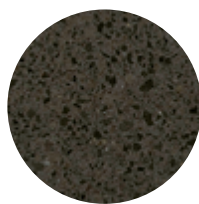

NG. Noir

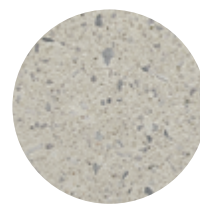

BL. Blanc

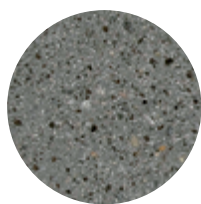

CA. Gris CA

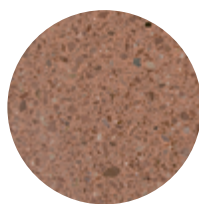

RA. Rouge

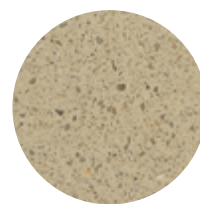

BG. Beige

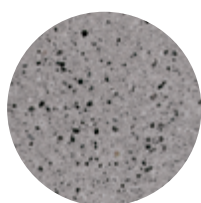

EGR. Gris Eco-Grey®

3.2 Système de pose

Élévation

(P=972 kg)

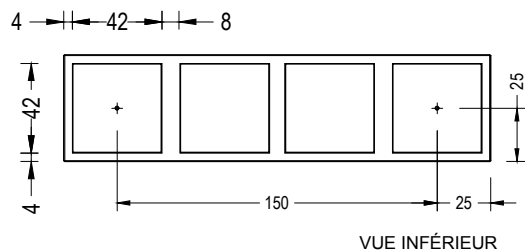
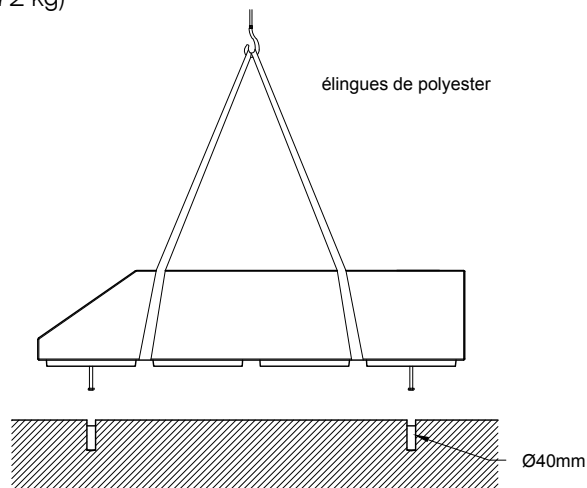

3.3 Géométrie

Box Terminal

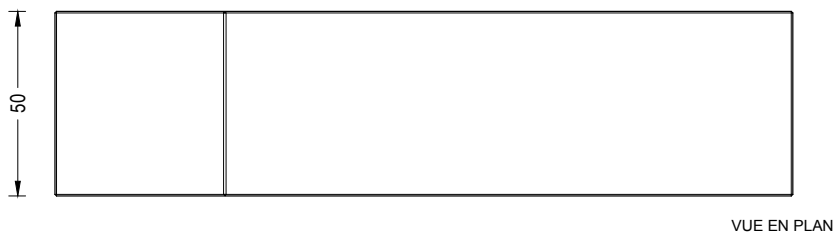
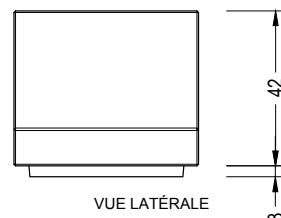
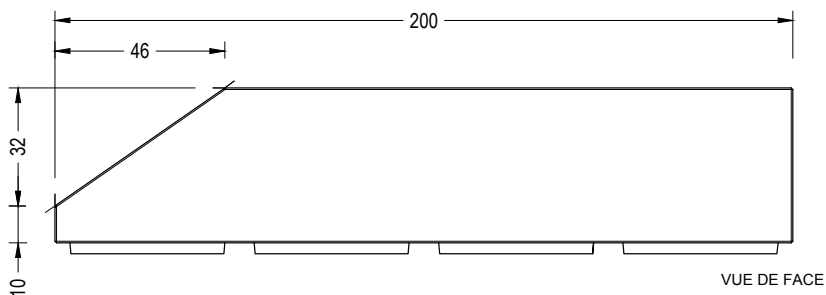

4. Box Planter

Box Planter	Rectangular	Square
Dimensions	200 x 50 x 45 cm	100 x 100 x 45 cm
Poids	534 kg	475 kg
Capacité	220 L	245 L

4.1 Caractéristiques générales

Matériel	Betón Béton recyclé	Pose	Simplement appuyée Fixation avec vis
-----------------	------------------------	-------------	---

Finition Sablé et hydrofugé

Couleurs

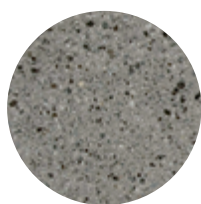

GR. Gris

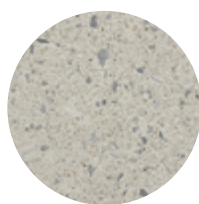

BL. Blanc

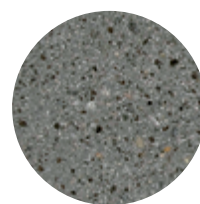

CA. Gris CA

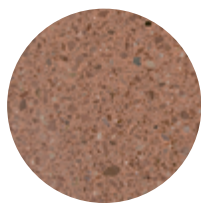

RA. Rouge

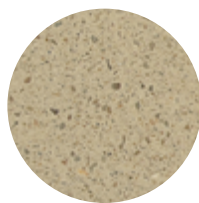

BG. Beige

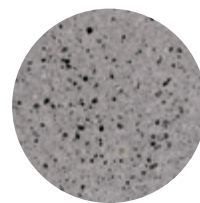

EGR. Gris Eco-Grey®

4.2 Système de pose

Élévation

P= 534 kg (avec terreau 908 kg) /
475 kg (avec terreau 892 kg)

Installation

Enfilez les 2 vis inférieures M16 x 140 mm.
Perce le trottoir (Ø40x180 mm) et remplir
avec de la résine ou mortier liquide. Ensuite,
centre, placez la jardinière et coupez la zone
de support.

Box Planter est fourni avec deux ou-
vertures intégrées dans le socle pour
permettre le déplacement avec un chariot
élévateur à fourche.

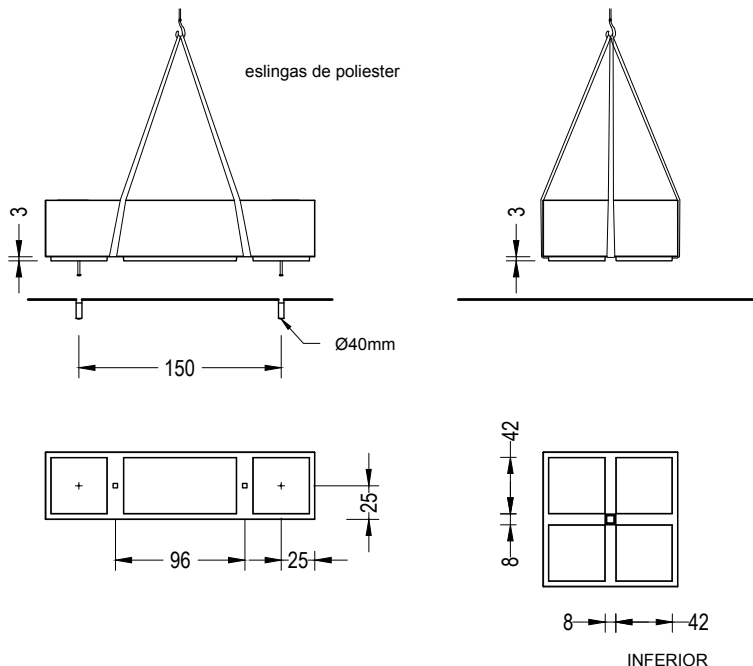
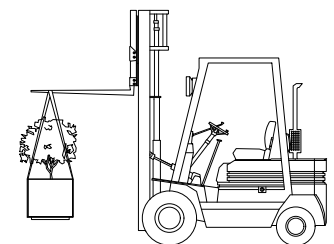

4.3 Géométrie

Box Planter Rectangular

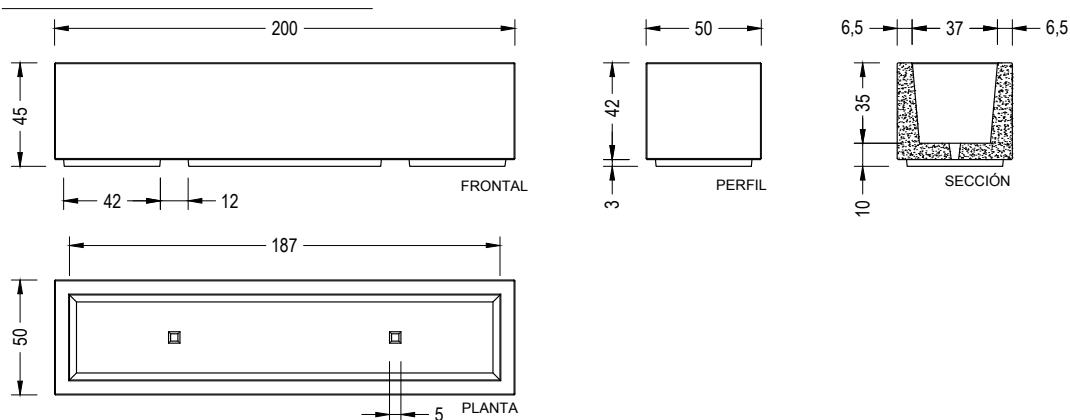

Box Planter Square

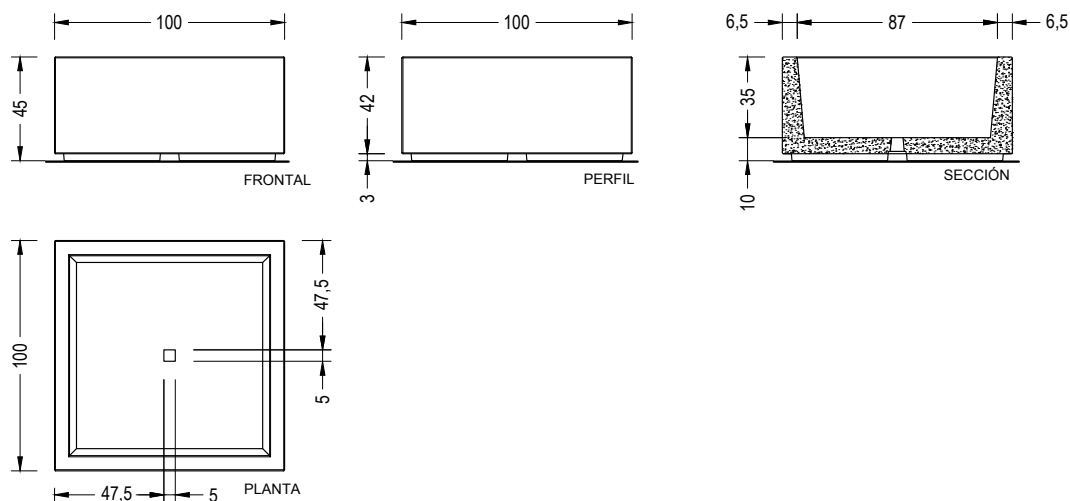

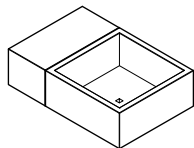

Box Planter Square, Box 100

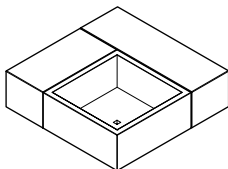

Box Planter Square, Box 100, 150

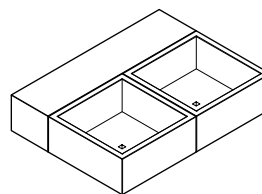

Box Planter Square, Box 200

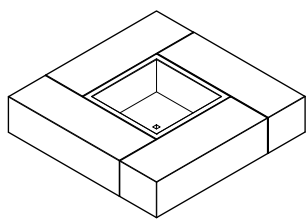

Box Planter Square, Box 150

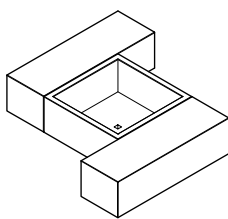

Box Planter Square, Box 150

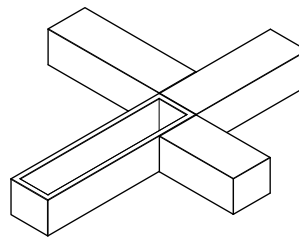

Box Planter Square, Box 100, 150

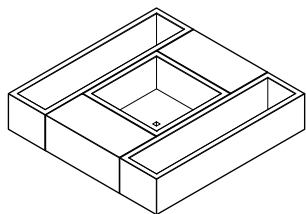

Box Planter Square, Box Planter Rectangular, Box 100

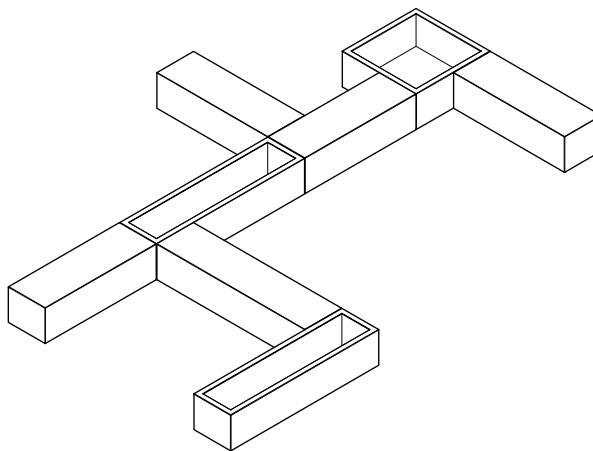

Box Planter Square, Box Planter Rectangular, Box 150, 200

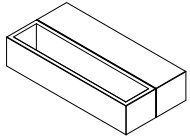

Box 200 + Box Planter

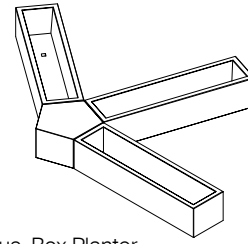

Box Nexus, Box Planter

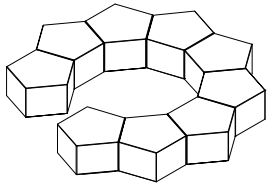

Box Nexus

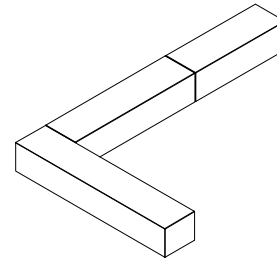

Box 150, 200, 250

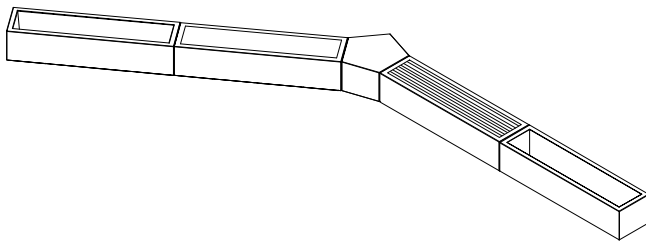

Box Planter, Box Nexus, Box 200 Teca

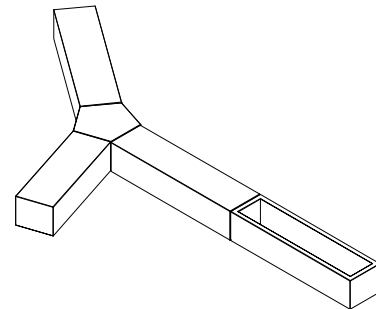

Box 150, 200, Box Nexus, Box Planter

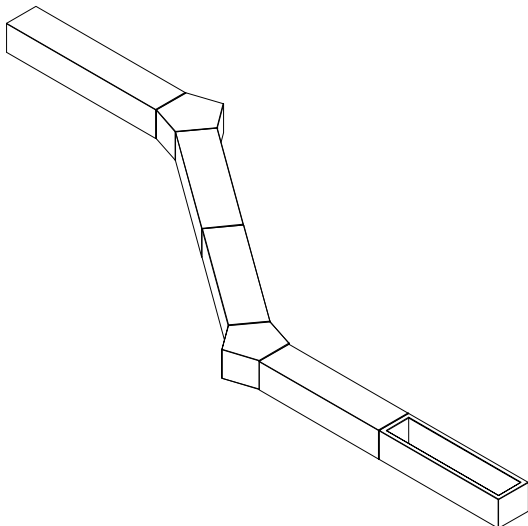

Box Planter, Box Nexus, Box 200, 250

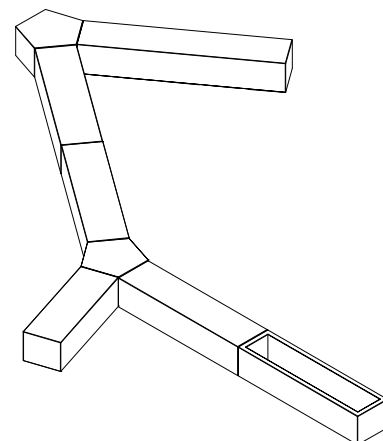

Box Planter, Box Nexus, Box 200, 250

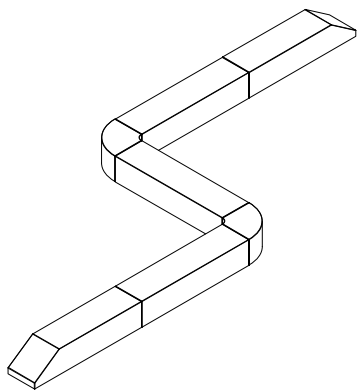

Box 200, Box Radius, Box Radius 90

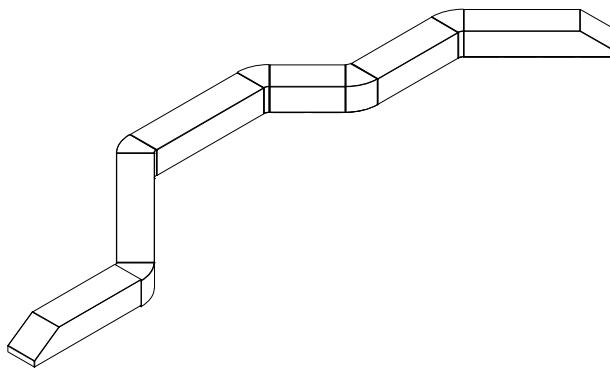

Box Terminal, Box Radius 45, Box 250,
Box 200, Box 150, Box 100

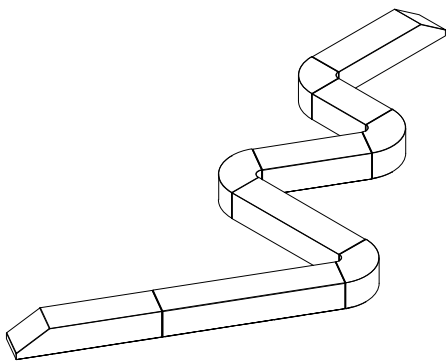

Box Terminal, Box Radius 120, Box Radius 90,
Box 250, Box 200, Box 150, Box 100

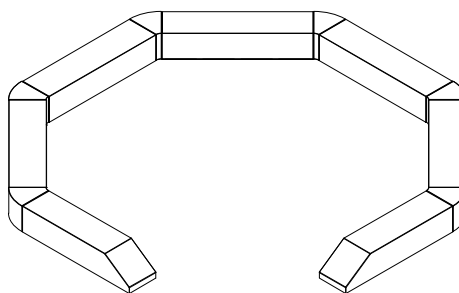

Box 150, 200, 250

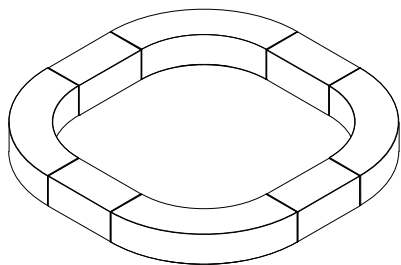

Box Curve, Box 100

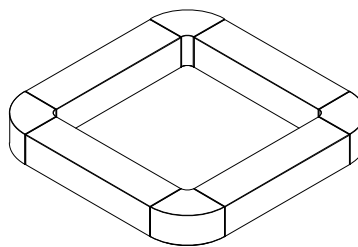

Box Radius 90, Box 250

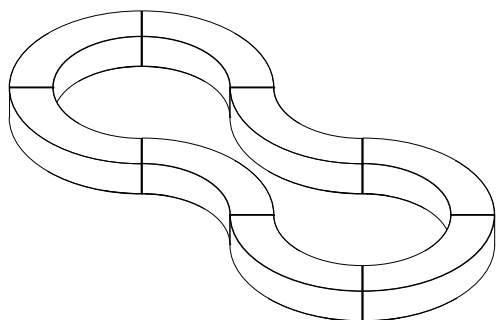

Box Curve

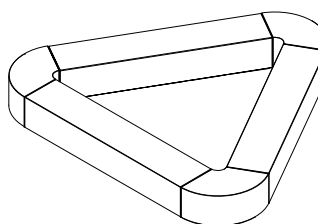

Box Radius 120, Box 250

BOXLAND





Garantie

5 années sur les composants de béton.

Les noms, marques et modèles industriels des produits ont été déposés au registre correspondant. Les informations techniques de ce document peuvent être modifiées sans préavis.

Escofet 1886 S.A
Siège et production

Montserrat, 162
E 08760 Martorell
Barcelona - España
T. 0034 937 737 150
F. 0034 937 737 151

info@escofet.com
www.escofet.com