

Kelly is a contemporary site furnishing collection formed by a bench, chair and backless bench, modelled with a printed cashmere type surface texture using the pioneering Escofet “Slimconcrete” technology. The result is a collection of elements with a familiar appearance that tackles urban space with a new approach in which the boundaries of inside and outside merge through new shapes that add beauty.

UHPC | 📏 130 cm/max | ⚖️ 200 kg | 🪑 2

🔄 Update 07.11.2019



Origin

In the words of the author: “When I first visited Escofet, I discovered a universe of fabulous shapes displayed in concrete, a great heritage of pavements that are instantly identifiable and unique in a number of cities. The objective was to design an object that combined the vast experience and tradition of the brand in creating concrete products and resolve the dilemma of why site furnishings should be so hopelessly plain. The incorporation of texture allow the seats to take on the appearance of sofas, arousing the curiosity of the user to look beyond the object itself”.

Material

The three elements of the Kelly collection are made from monobloc UHPC-Slimconcrete pieces reinforced with stainless steel and with a printed cashmere-like texture on all their contact surfaces. With an etched soft finish and colour in accordance with the standard Escofet colour chart.

Installation

The bench, chair and backless bench are anchored with sleeves and threaded M10 x 100 rods to 40 mm holes in the paving filled with resin or fat mortar.



KELLY



Escofet®

1. Bench

Kelly	Bench	Chair	Backless bench
Dimensions	130 x 58 x 45 (80) cm	79 x 65 x 46 (78) cm	130 x 41 x 45 (55) cm
Weight	200 kg	140 kg	110 kg
1.1 General features			
Material	UHPC Concrete	Fixing	Anchored with screws
Finish	Colour waterproof	Texture	Interior floral relief

Colours

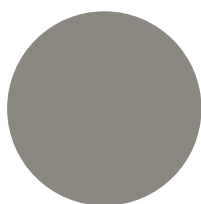

UHPC GR. Grey

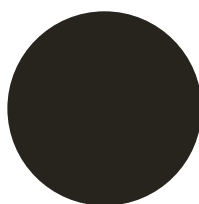

UHPC NG. Black



UHPC BL. White

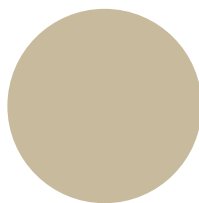

UHPC BG. Beige

1.2 Installation system

Hoisting

(P=200/ 140 / 110 Kg)

Installation

Drill pavement (Ø 14 mm) and fill with resin or fat mortar. Tightly screw the 4 stud bolts M-10 x 100 mm. Center and caulk the bench and foot all around.

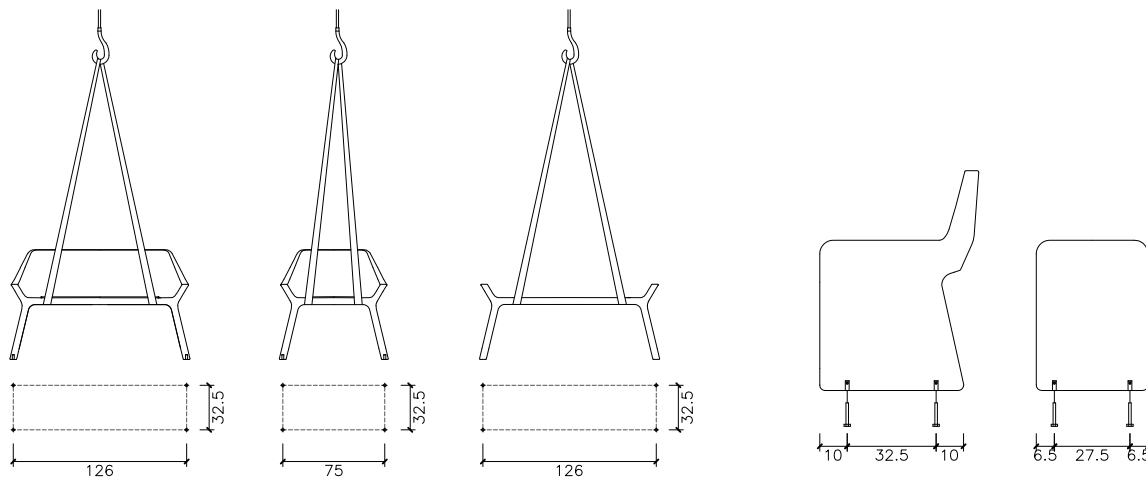

1.3 Geometry

Kelly Bench

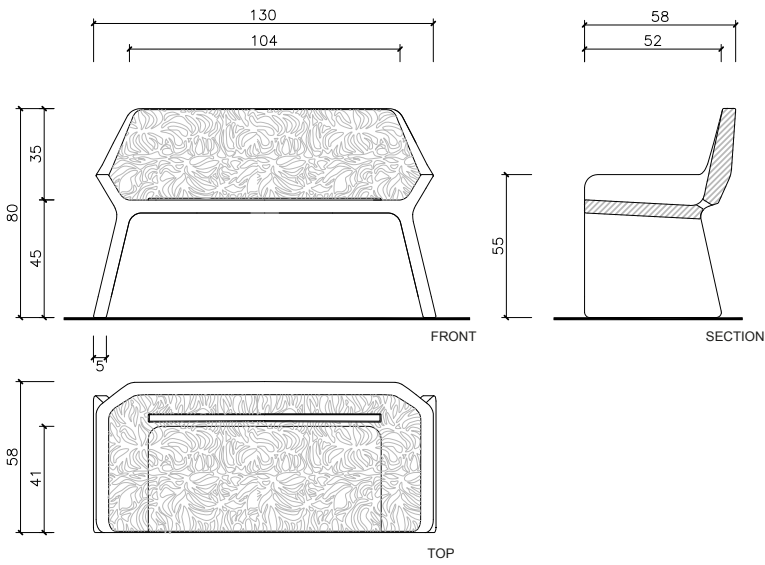

Kelly Chair

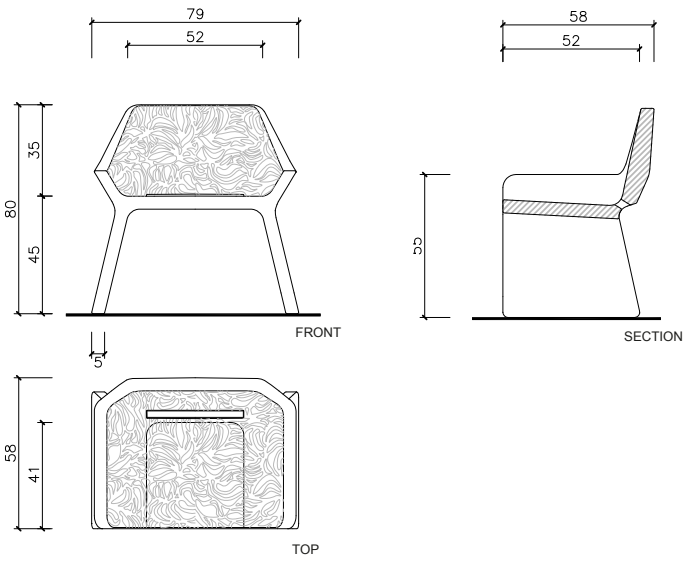

Kelly Backless bench

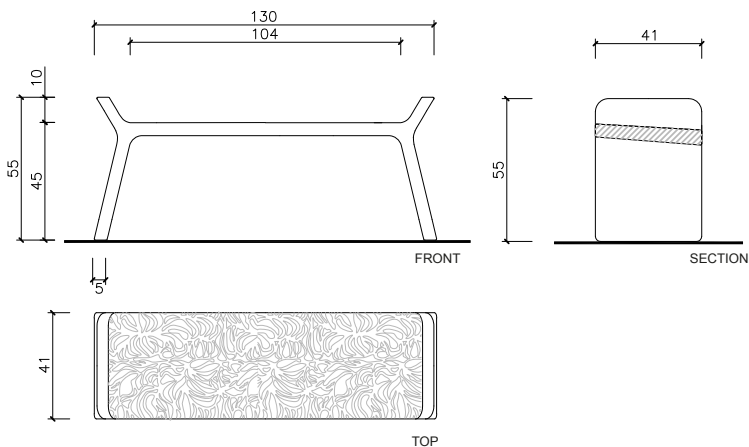



Warranty

5 years in all its components.

The names, trademarks and industrial models of the products have been logged in the corresponding registers. The technical information provided by Escofet about its products can be modified without prior notice.

Escofet 1886 S.A
Head office and production

Montserrat, 162
E 08760 Martorell
Barcelona - España
T. 0034 937 737 150
F. 0034 937 737 151

info@escofet.com
www.escofet.com



GA-2005/0072 SST-0090/2010 ER-0403/2016